



# IDP-801

## Interactive Display Panel

*Instruction Manual*



For use with  
DECS-250, DECS-250N, DECS-250E, DECS-400, or DECS-450  
Digital Excitation Control Systems

 **WARNING:** California's Proposition 65 requires special warnings for products that may contain chemicals known to the state of California to cause cancer, birth defects or other reproductive harm. Please note that by posting this Proposition 65 warning, we are notifying you that one or more of the Proposition 65 listed chemicals may be present in products we sell to you. For more information about the specific chemicals found in this product, please visit <https://www.basler.com/Prop65>.

# Preface

This instruction manual provides information about the installation and operation of the IDP-801 Interactive Display Panel. To accomplish this, the following information is provided:

- Mounting and connections
- Communication requirements
- Display operation and screen navigation
- Product specifications

## ***Conventions Used in this Manual***

---

Important safety and procedural information is emphasized and presented in this manual through warning, caution, and note boxes. Each type is illustrated and defined as follows.

### **Warning!**

Warning boxes call attention to conditions or actions that may cause personal injury or death.

### **Caution**

Caution boxes call attention to operating conditions that may lead to equipment or property damage.

### **Note**

Note boxes emphasize important information pertaining to installation or operation.



12570 State Route 143  
Highland IL 62249-1074 USA

[www.basler.com](http://www.basler.com)

[info@basler.com](mailto:info@basler.com)

Tel: +1 618.654.2341

Fax: +1 618.654.2351

© 2026 by Basler Electric

All rights reserved

First printing: November 2015

## Warning!

**READ THIS MANUAL.** Read this manual before installing, operating, or maintaining the IDP-801. Note all warnings, cautions, and notes in this manual as well as on the product. Keep this manual with the product for reference. Only qualified personnel should install, operate, or service this system. Failure to follow warning and cautionary labels may result in personal injury or property damage. Exercise caution at all times.

Basler Electric does not assume any responsibility to compliance or noncompliance with national code, local code, or any other applicable code. This manual serves as reference material that must be well understood prior to installation, operation, or maintenance.

For terms of service relating to this product and software, see the *Commercial Terms of Products and Services* document available at [www.basler.com/customer-terms-and-conditions](http://www.basler.com/customer-terms-and-conditions).

This publication contains confidential information of Basler Electric Company, an Illinois corporation. It is loaned for confidential use, subject to return on request, and with the mutual understanding that it will not be used in any manner detrimental to the interests of Basler Electric Company and used strictly for the purpose intended.

It is not the intention of this manual to cover all details and variations in equipment, nor does this manual provide data for every possible contingency regarding installation or operation. The availability and design of all features and options are subject to modification without notice. Over time, improvements and revisions may be made to this publication. Before performing any of the following procedures, contact Basler Electric for the latest revision of this manual.

The English-language version of this manual serves as the only approved manual version.

# Revision History

The following information provides a historical summary of the changes made to this manual. Revisions are listed in reverse-chronological order.

Manual Revision, Date	Description
G, Apr 2026	<ul style="list-style-type: none"> <li>Removed references to SD card as included hardware</li> </ul>
F, Mar 2026	<ul style="list-style-type: none"> <li>Re-added <i>Maintenance and Troubleshooting</i> and <i>Specifications</i> chapters</li> <li>Updated accessory part numbers</li> </ul>
E, May 2021	<ul style="list-style-type: none"> <li>Improved and clarified the diagrams and descriptions in the <i>Communication</i> chapter</li> <li>Added recommendation against display panel exposure to sunlight</li> <li>Added clarification about referring to the DECS-400 and DECS-450 instruction manuals for Modbus register information for those products</li> <li>Added notes boxes indicating that settings-level password access is required in order for the IDP-801 to successfully reset DECS alarms</li> </ul>
D, Jul 2020	<ul style="list-style-type: none"> <li>Added coverage of IDP-801 style E (IDP-801-E) for use with the DECS-450</li> </ul>
C, Jun 2017	<ul style="list-style-type: none"> <li>Added coverage of DECS start/stop control and the corresponding password protection</li> </ul>
B, Feb 2017	<ul style="list-style-type: none"> <li>Added caution statement about nonvolatile memory</li> <li>Added coverage of IDP-801 style D (IDP-801-D)</li> </ul>
A, Aug 2016	<ul style="list-style-type: none"> <li>Added DECS-250E as a product compatible with the IDP-801</li> </ul>
—, Nov 2015	<ul style="list-style-type: none"> <li>Initial release</li> </ul>



# Contents

Introduction .....	1-1
Communication.....	2-1
IDP-801-B Operation.....	3-1
IDP-801-C and IDP-801-D Operation.....	4-1
IDP-801-E Operation.....	5-1
Modbus® Communication.....	6-1
Mounting .....	7-1
Connections.....	8-1
Maintenance and Troubleshooting .....	9-1
Specifications .....	10-1



# 1 • Introduction

The IDP-801 Interactive Display Panel is a 7.5 inch/19 centimeter (measured diagonally) color touchscreen interface that enables a user to monitor and control a Basler Electric DECS-based excitation system. IDP-801 monitoring and control features include DECS and excitation system status, system control operations, and routine adjustments of the excitation setpoint. The IDP-801 is compatible with DECS-250, DECS-250N, DECS-250E, DECS-400, and DECS-450 Digital Excitation Control Systems.

DECS and synchronous machine system parameters are viewed and controlled through interactive pages displayed by the IDP-801. Pages are organized according to system functions. Navigation between pages and control of functions is achieved by touching buttons located on the IDP-801 pages.

Communication between the IDP-801 and DECS is facilitated through the serial communication port of the IDP-801 and the RS-485 port of the DECS. One IDP-801 can monitor both the primary and secondary DECS in a dual DECS application. The IDP-801 is equipped with an Ethernet communication port which provides access to Modbus® registers for system monitoring and control of the DECS. This capability enables integration of the IDP-801 into an existing Distributed Control System (DCS).

## ***IDP-801 Style Designations***

A single-digit style designator determines the DECS application that is compatible with the IDP-801. Style options are shown in Figure 1-1.

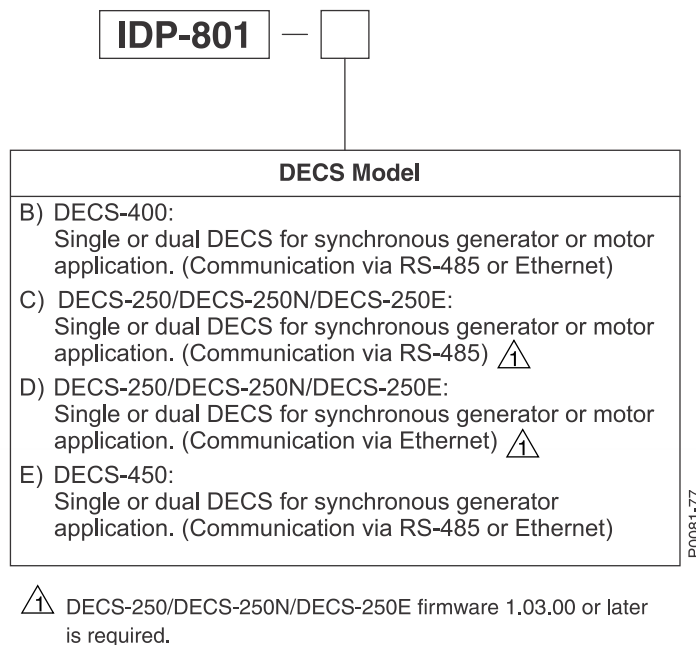

**Figure 1-1. IDP-801 Style Options**

## ***Application***

The IDP-801 serves as the successor to the IDP-800. Other than slight differences in its connectors and their layout, the IDP-801 is virtually identical to the IDP-800 in form and function. Replacement of an IDP-800 with an IDP-801 requires no modification of the mounting panel and only a slight adjustment to the control power connections.

IDP-801 and IDP-800 features are compared in Table 1-1.

Table 1-1. IDP-801 and IDP-800 Features Comparison

Features		IDP-800	IDP-801
Display Type		TFT Color LCD	
Display Resolution		VGA (640 x 480 pixels)	
Backlight		Fluorescent	LED
Border Color		Silver	Gray
Panel Cutout Dimensions		8.05"W x 6.28"H (204.5 mm x 159.5 mm)	
External Dimensions		8.46"W x 6.69"H x 2.36"D (215 mm x 170 mm x 60 mm)	8.58"W x 6.85"H x 2.36"D (218 mm x 174 mm x 60 mm)
Memory	Application	16 MB	32 MB
	SRAM	320 KB	512 KB
	External Card	Compact Flash Type II	SDHC (not included)
Nominal Input Voltage		24 Vdc	
Power Consumption		28 W or less	12 W or less
Temperature	Operating	0 to 122°F (0 to 50°C)	0 to 131°F (0 to 55°C)
	Storage	-4 to 140°F (-20 to 60°C)	
Humidity		10 to 90% noncondensing	
Serial	COM 1	D-Sub, 9-pin (plug) RS-232C/422/485	D-Sub, 9-pin (plug) RS-232C
	COM 2	D-Sub, 9-pin (socket) RS-422/485	D-Sub, 9-pin (plug) RS-422/485
Ethernet	Type	10Base-T/100Base-TX	
	Location	Bottom of case	
USB	Type A	1 port	1 port
	Type B	No	1 port
	Location	Bottom of case	Bottom of case and Right Side
Front Panel LED State	Green	Normal operation, internal logic running	
	Green (Flashing)	Normal operation, internal logic stopped	
	Red	Hardware initialization upon application of control power	
	Red (Flashing)	In operation, internal logic execution error	
	Orange	Backlight failure	n/a
	Orange (Flashing)	Internal logic startup	
Agency/Certification	CE Compliance	Yes	
	UL Recognized	Yes	
	RoHS	Yes	
	ABS	Yes	
	DNV	Yes	
	ATEX	Yes	No





## 2 • Communication

The communication method available to exchange data and commands between the IDP-801 and DECS controller depends upon the IDP-801 style and DECS model. Communication methods include serial and/or Ethernet. When connected to an Ethernet LAN, the IDP-801 can be polled via Modbus® to acquire data collected by the DECS.

### Caution

This product contains one or more *nonvolatile memory* devices. Nonvolatile memory is used to store information (such as settings) that needs to be preserved when the product is power-cycled or otherwise restarted. Established nonvolatile memory technologies have a physical limit on the number of times they can be erased and written. During product application, consideration should be given to communications, logic, and other factors that may cause frequent/repeated writes of settings or other information that is retained by the product. Applications that result in such frequent/repeated writes may reduce the useable product life and result in loss of information and/or product inoperability.

### ***IDP-801 Applications and Communication Methods***

IDP-801 applications and communication methods are summarized in Table 2-1.

**Table 2-1. DECS and IDP-801 Communication Applications**

DECS Model	IDP-801 Style	Communication	
		Method	Scheme
DECS-250	IDP-801-C	Serial, RS-485	Figure 2-1
DECS-250	IDP-801-D	Ethernet	Figure 2-2
DECS-250E	IDP-801-C	Serial, RS-485	Figure 2-1
DECS-250E	IDP-801D	Ethernet	Figure 2-2
DECS-250N	IDP-801C	Serial, RS-485	Figure 2-1
DECS-250N	IDP-801-D	Ethernet	Figure 2-2
DECS-400	IDP-801-B	Serial, RS-485 or Ethernet *	Figure 2-2
DECS-450	IDP-801-E	Serial, RS-485 or Ethernet	Figure 2-2

\* Requires a multi-port Ethernet switch between an IDP-801-B and single- or dual-DECS-400 controllers. An open port on the switch enables external (DCS) control and monitoring communication between the IDP-801 and DECS-400.

### **Serial Communication**

When the IDP-801 will be communicating with a DECS using RS-485 serial communication, the DECS communication settings should be configured as follows:

- Baud: 9600
- Data length: 8
- Parity: None
- Stop bits: 2
- Single DECS address: 247
- Dual DECS address: 247 (DECS-A) and 246 (DECS-B)

## Ethernet Communication

An Ethernet port enables the IDP-801 to be polled over a LAN/Distributed Control System (DCS) and provides values of system parameters monitored by the DECS. An Ethernet port on the DECS-250, DECS-250E, DECS-250N, DECS-400, and DECS-450 enables communication with the IDP-801 at higher speeds than possible through the RS-485 port.

IDP-801 Modbus registers for the available DECS functions are listed in the *Modbus Communication* chapter. Specific information about the Modbus communication protocol, as it is employed by the DECS is provided in Basler publication 9440300990 (DECS-250), 9440500990 (DECS-250N), 9504000990 (DECS-250E), 9369700990 (DECS-400), and 9597100990 (DECS-450).

## Typical Applications: IDP-801-C

A typical IDP-801-C application is shown in Figure 2-1 where IDP-801-C display panels communicate via RS-485 with DECS-250, DECS-250E, or DECS-250N controllers.

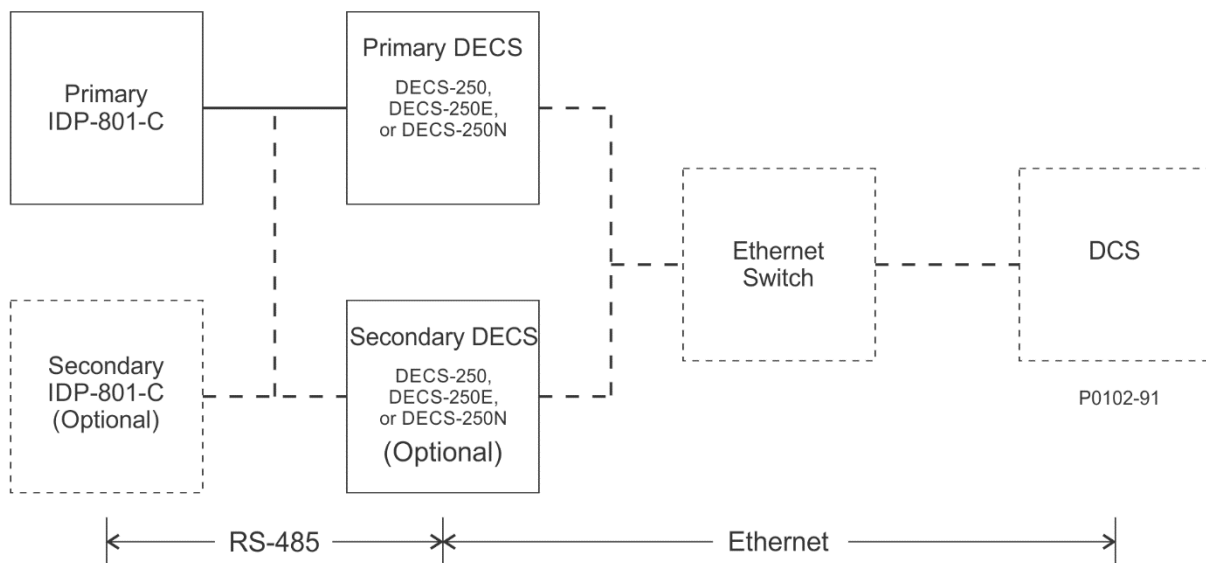

Figure 2-1. IDP-801-C with DECS-250/DECS-250E/DECS-250N

## Typical Applications: IDP-801-B, IDP-801-D, and IDP-801-E

When more than one IDP-801 is used in an application, it is recommended that all display panels of the same style be applied.

An Ethernet switch is used to route IDP-801 and DECS communication over a LAN. For a DECS-250, DECS-250E, or DECS-250N application, an IDP-801-D is used. For a DECS-400 application, an IDP-801-B is used. For a DECS-450 application, an IDP-801-E is used.

A typical LAN communication scheme for an IDP-801-B, IDP-801-D, or IDP-801-E is illustrated in Figure 2-2.

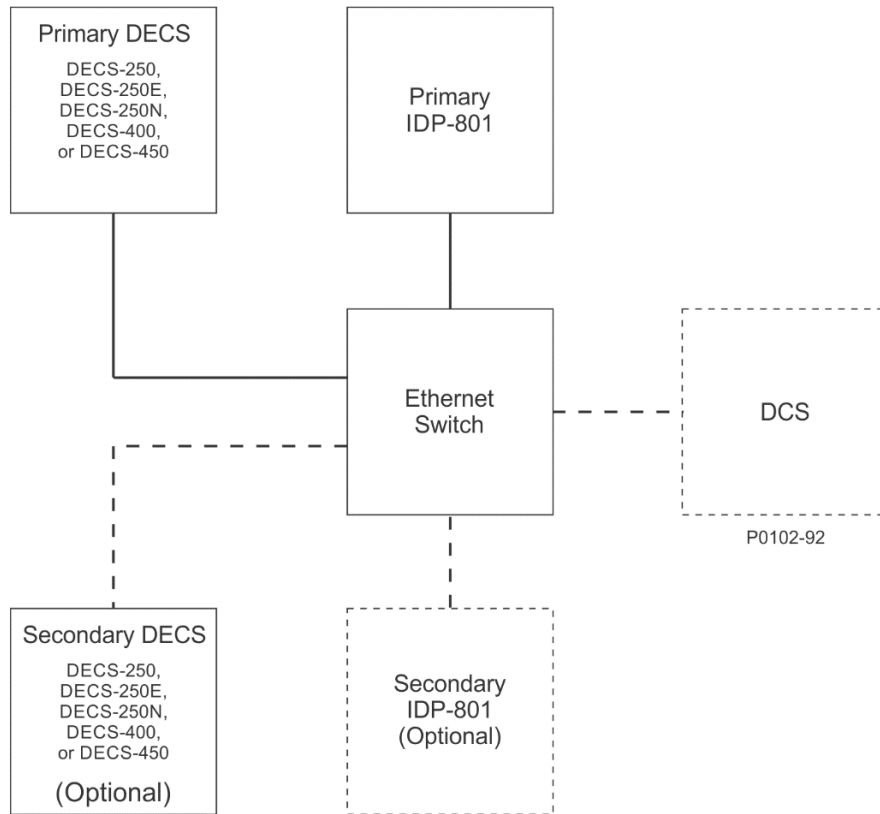

Figure 2-2. IDP-801-B with DECS-400, IDP-801-D with DECS-250/DECS-250E/DECS-250N, or IDP-801-E with DECS-450

### Alternate IDP-801 Applications

When more than one IDP-801 is used in an application, it is recommended that all display panels of the same style be applied. However, it is possible to apply an IDP-801-C and IDP-801-D in the same installation. Figure 2-3 illustrates an example of a mixed-style application.

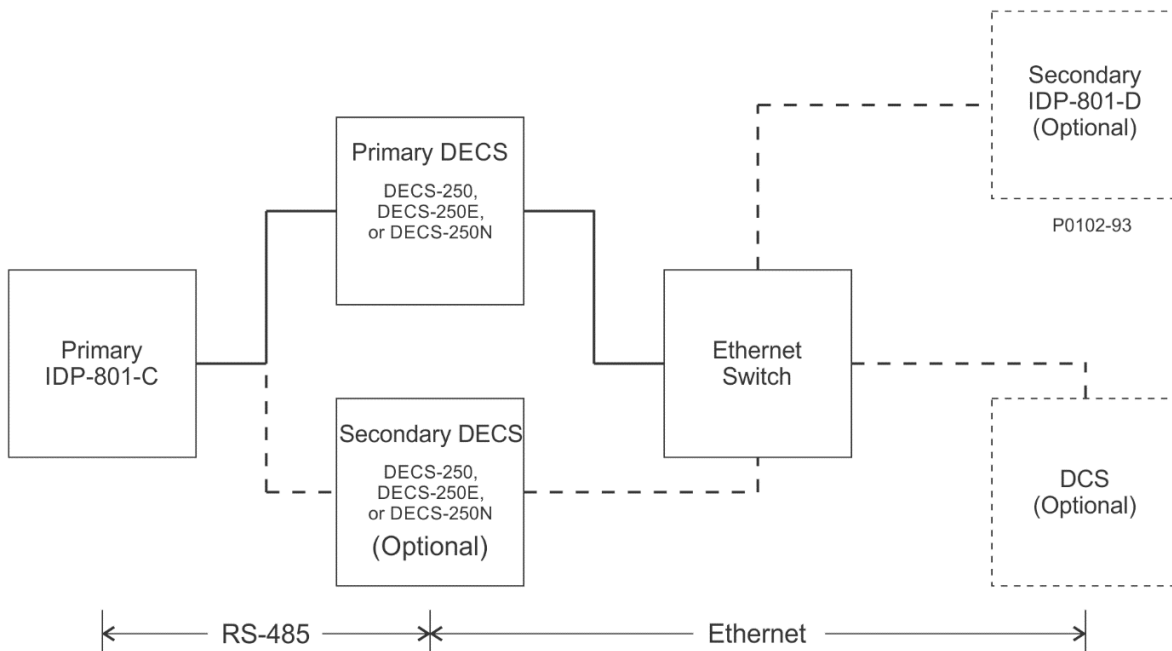

Figure 2-3. IDP-801-C and IDP-801-D with DECS-250/DECS-250E/DECS-250N

## ***IDP-801 Polling Configuration***

---

For IDP-801 polling to take place, its IP address must be configured to accommodate your Ethernet LAN. Perform the following steps to view the IDP-801 communication settings and configure its IP address.

### **Caution**

The following procedure must be performed with the generator or motor offline. Communication between the IDP-801 and DECS will cease during configuration of the IP address.

1. Press the upper, right corner of the display screen followed by the lower, left corner in quick succession.
2. Press the **Offline** button.
3. When prompted, enter the offline mode access password. The factory-default password is "basler".
4. At the next prompt, enter the system password. The factory-default password is "4376".
5. Press the **Main Unit Settings** button.
6. Press the **Ethernet Local Settings** button.
7. Configure the IP address to be compatible with your network. If needed, consult your network administrator for the proper settings.
8. Press the **Exit** button.
9. Press the **Yes** button. The display will restart and activate the new communication settings.

## 3 • IDP-801-B Operation

The IDP-801-B is applied in applications using the DECS-400. See the IDP-801 style chart for IDP-801 style definitions. This chapter describes IDP-801-B operation and screen navigation. For DECS-250, DECS-250N, and DECS-250E applications, see the *IDP-801-C Operation* chapter.

IDP-801 screen appearance and availability will vary according to the type of DECS used and the configuration of the DECS system (single or dual DECS and generator or motor control).

DECS and generator/motor system parameters are viewed and controlled through interactive screens displayed by the IDP-801. Screens are organized according to function. Navigation between screens and control of functions are achieved by touching “buttons” on the IDP-801 screens.

### Configuration Screens

Two configuration screens establish DECS and IDP-801 operating modes: IDP-801 Configuration and Screen Configuration. These configuration screens are available upon initial power-up of the IDP-801. After initial configuration, these screens can be accessed through the Main View screen by entering the appropriate password.

#### IDP-801 Configuration

Upon initial power-up, the IDP-801 displays the IDP-801 Configuration screen (Figure 3-1) where your product, product configuration, application, and communication method must be selected before proceeding to other IDP-801 screens. Failure to make the proper selections may cause the IDP-801 to annunciate false alarms.

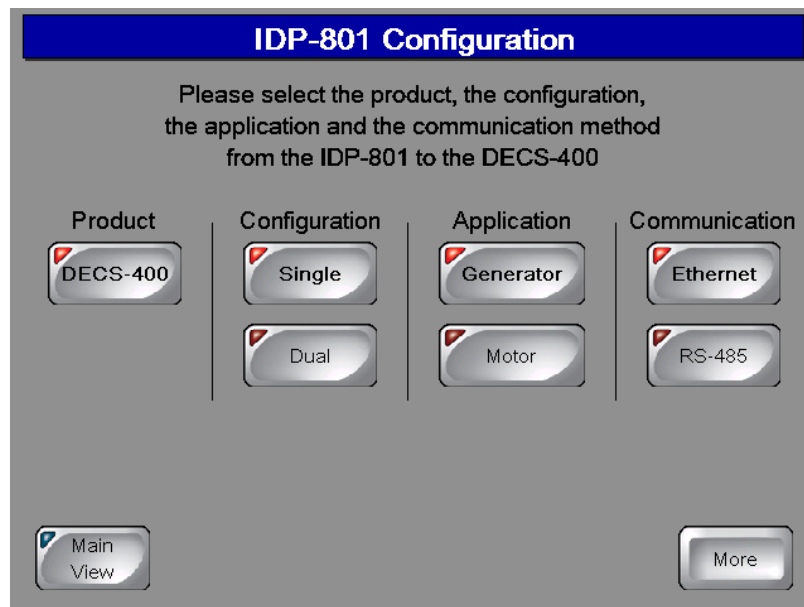

Figure 3-1. IDP-801 Configuration Screen

#### Screen Configuration

Pressing the More button on the IDP-801 Configuration screen accesses the Screen Configuration screen (Figure 3-2) which enables selection of the IDP-801 language and other operating preferences. Individual screen preferences are described in the following paragraphs.

### Language

Pressing the English (Anglais or Inglés) button selects English as the IDP-801 display language. Pressing the French (Français or Francés) button selects French as the display language. Pressing the Spanish (Español or Español) button selects Spanish as the display language.

### Date and Time

The date and time of an IDP-801 connected to a DECS-400 is automatically synchronized with the date (month, day, and year) and time (hours and minutes) maintained by the DECS-400.

### 52L/M Input Switch Number

These buttons configure the IDP-801 to monitor the same contact inputs that the DECS-400 is monitoring for the 52L/M contact input. Pressing the Standard Logic button configures the IDP-801 to monitor contact input 3 for 52L/M contact status, which is the default assignment in standard DECS-400 logic. Pressing the Customized Logic button enables the user to configure the IDP-801 to monitor the 52L/M contact input as configured in the customized DECS-400 logic.

### Start/Stop Buttons Hidden/Visible

Pressing this button enables and disables visibility of the Start and Stop buttons on the DECS Control screen.

### Records Duration

Trending records saved by the IDP-801 retain up to six variables per record with each record consisting of 2,400 data points. Trending records saved by the IDP-801 can have a user-defined duration ranging from 1 hour to 720 hours (30 days). Note: requires installation of an SD/SDHC memory card.

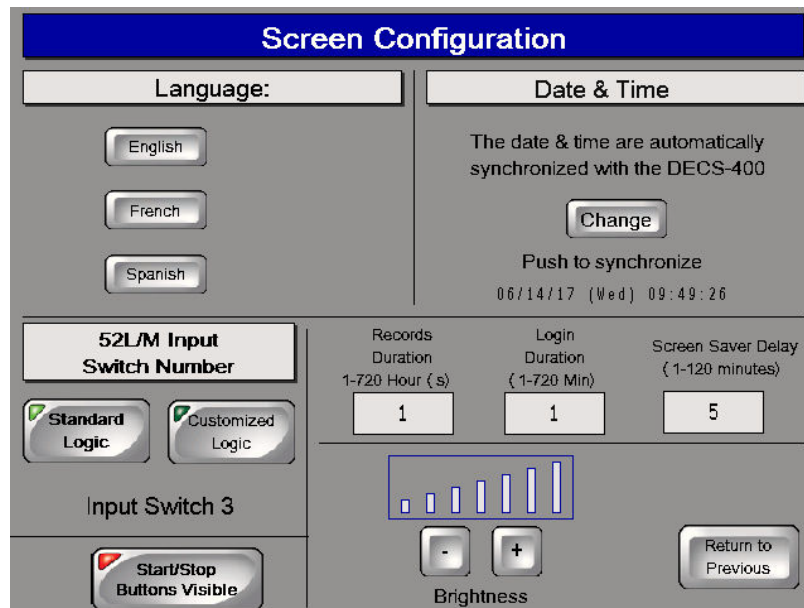

**Figure 3-2. Screen Configuration Screen**

### Login Duration

Following login, the length of time that password access is available (if no button presses occur) is limited by the value of this setting. If no button presses are received for the duration of the setting, password access is lost and the user must log in again to make changes requiring password access. Login Duration is adjustable over the range of 1 to 720 minutes (12 hours).

### Screen Saver Delay

A screensaver activates if no button presses are received at the display panel for the length of time specified by the Screen Saver Delay. A setting of 1 to 120 minutes may be entered.

### Brightness

Display panel brightness can be increased and reduced by pressing the “+” and “-” buttons. A bar graph above the buttons serves as a reference for adjusting the display brightness.

## **Main View Screen**

This screen (Figure 3-3) serves as a gateway to the IDP-801 status and control screens. It also provides access to file transfer functions and a screen lock to enable panel cleaning. The Login button can be used to enter the appropriate password and gain access to the configuration screens.

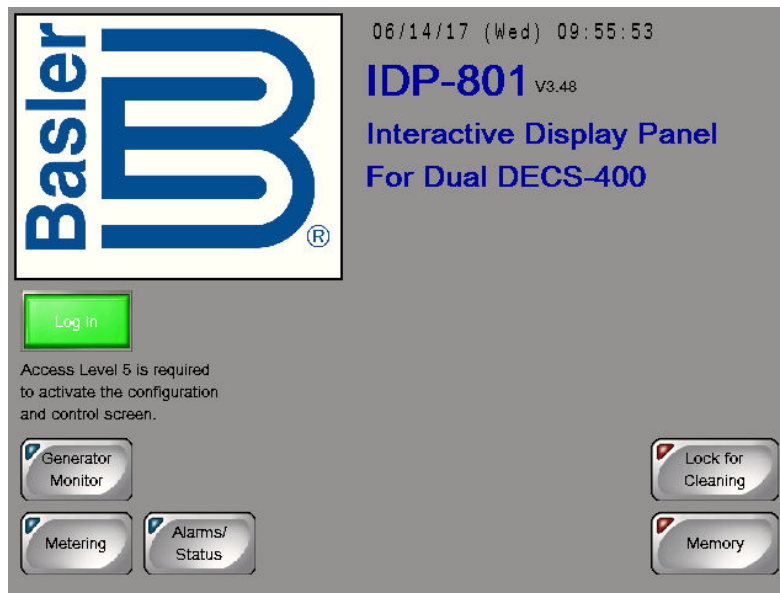

**Figure 3-3. Main View Screen**

Access to the Control button (and control screens) is possible only when logged into the IDP-801 with the correct password.

### **IDP-801 Passwords**

Passwords protect the IDP-801 from unauthorized settings changes, control commands, and transfers offline.

Two of the passwords are used when transferring the IDP-801 offline. When taking the IDP-801 offline, the offline and system passwords are used. The IDP-801 is delivered with a system password of “4376” and an offline mode access password of “BASLER”.

A factory-default password of “idp8” gives (level 5) access to IDP-801 configuration and control functions.

A factory-default password of “decs4” gives (level 1) access to only the IDP-801 control functions.

A factory-default password of “idpx” provides start and stop control (access level 6) of the DECS through the Start and Stop buttons of the DECS Control screen.

Password access remains in effect based on display panel activity and the limit set by the Login Duration setting (Screen Configuration screen).

### **Gaining Password Access**

The following example describes the process for using a password to gain configuration and control access.

1. Press the Login button on the Main View screen.
2. Use the alphanumeric keypad to enter the appropriate password and press the Enter button. The factory-default password is IDP8 and is case-sensitive.

Once the correct password is entered, the Main View screen is displayed with a Control button that provides access to the control screens and a Configure button that provides access to the configuration screens.

## Generator/Motor Monitor

Depending upon the application selected on the IDP-801 Configuration screen, either the Generator Monitor screen or Motor Monitor screen is accessed by pressing the Generator Monitor button or Motor Monitor button of the Main View screen. The Generator Monitor or Motor Monitor screen graphically illustrates generator/motor and excitation system status/activity. Generator and motor parameters include output voltage, output current, active (true) power, reactive power, and power factor. Excitation system parameters include field voltage, field current, and excitation on/off status. The Generator Monitor screen is shown in Figure 3-4 and the Motor Monitor screen is shown in Figure 3-5.

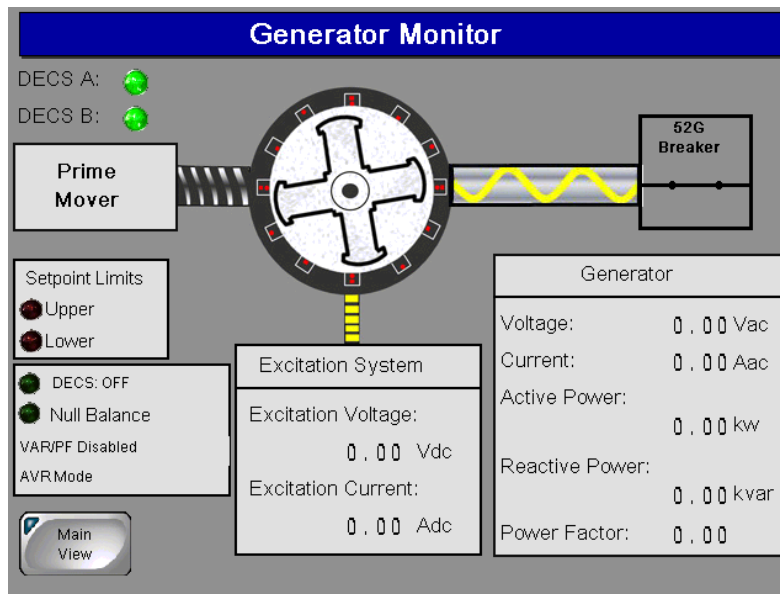

Figure 3-4. Generator Monitor Screen

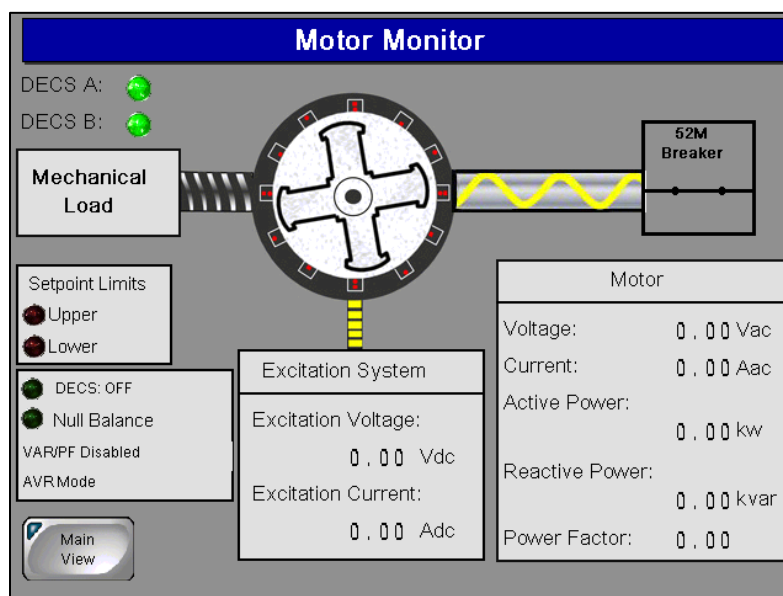

Figure 3-5. Motor Monitor Screen

## DECS Metering Screen

Access the DECS Metering screen (Figure 3-6) by pressing the Metering button of the Main View screen. The DECS Metering screen displays digital metering values for the generator or motor, bus, and exciter field as well as the excitation setpoint position and control values.

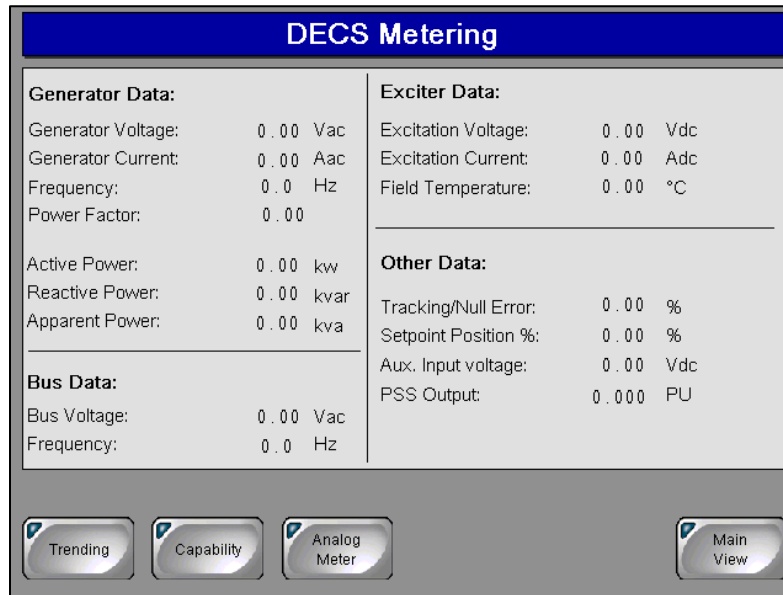

Figure 3-6. DECS Metering Screen

### Analog Metering

Pressing the Analog Meter button accesses the analog representations of the digital values displayed on the DECS Metering screen. Analog metering values are divided among three screens accessed through buttons labeled Generator Values, Generator Power, and Exciter Values. Each parameter is represented by an analog meter along with the digital version of the metered value.

### Trending

Access to the Trending and Capability Curve screens is also provided through the Trending and Capability buttons on the DECS Metering screen.

The Trending screen (Figure 3-7) is accessed by pressing the Trending button of the DECS Metering screen. Several system parameters can be selected and monitored over time in an amplitude-versus-time window. Buttons on the Trending screen enable selection of the parameters to be monitored. Available parameters include generator voltage (Vgen), apparent power (kVA), true power (kW), reactive power (kvar), field voltage (Vexc), and field current (Iexc). Parameters are plotted in a color that matches the color of the parameter buttons. Pressing the History button displays additional controls and a display for manipulating the cursor position within a data plot. Pressing the USB button accesses the Memory Transfer screen where the data from a trending plot can be transferred to USB memory device. Storage of trending information requires the installation of an SD/SDHC memory card.

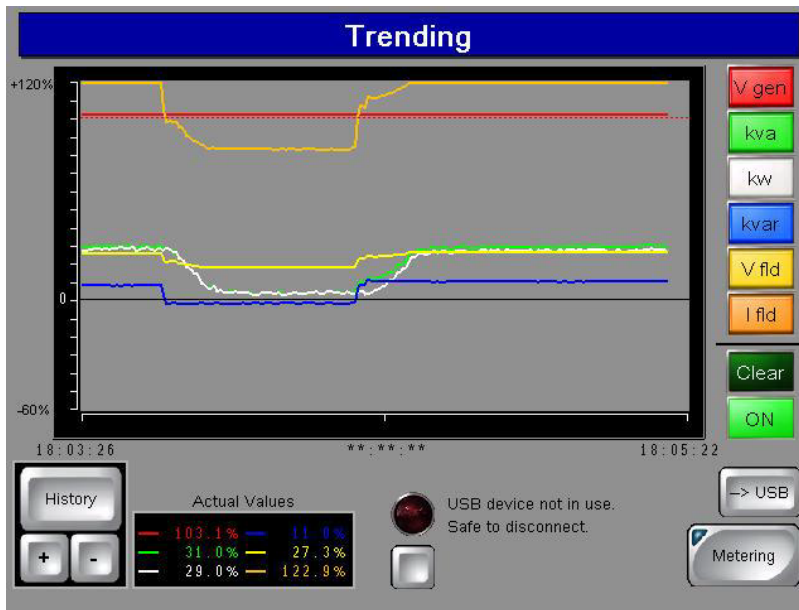

Figure 3-7. Trending Screen

## Capability

Access the Capability screen (Figure 3-8) by pressing the Capability button on the DECS Metering screen. By default, a horizontal curve is displayed. Pressing the Vertical Curve button selects a vertical curve orientation.

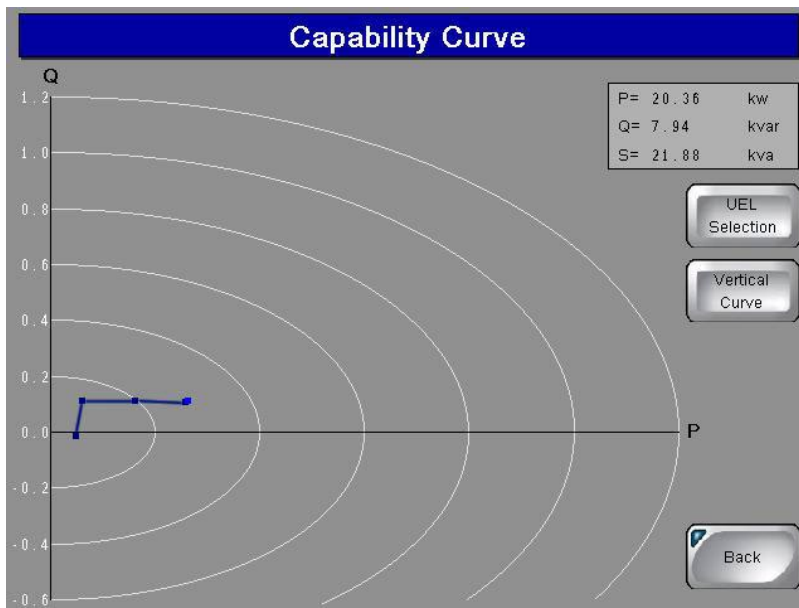

Figure 3-8. Capability Curve Screen

If a plot of the underexcitation limiter (UEL) curves is desired, the Internal UEL Curve button can be pressed to access the UEL Curve Selection screen (Figure 3-9). Here, the internal DECS UEL curve can be selected or a customized, three-, four-, or five-point curve can be selected and configured. UEL curve points must be selected in the DECS BESTCOMS software for an accurate representation on the IDP-801. Pressing the None button disables the display of UEL curves.

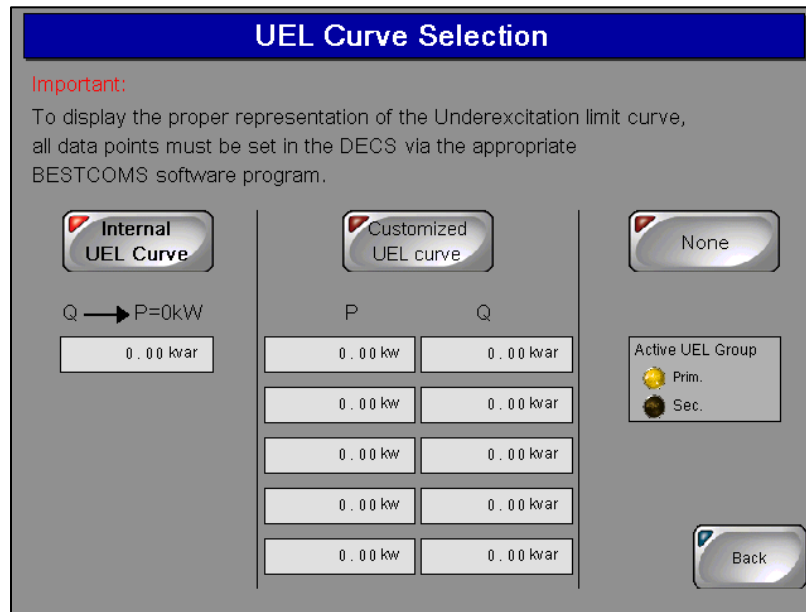

Figure 3-9. UEL Curve Selection Screen

## DECS Analog Metering

Analog representations of the digital metering values shown on the DECS Metering screen (Figure 3-6) can be accessed by pressing the Analog Meter button. Pressing this button accesses the Generator Values or Motor Values screen which displays analog representations of the generator/motor voltage, current, frequency, and power factor. Each analog representation displays the digital equivalent in the upper, left corner. The remaining analog metering values are divided between two screens: the Generator Power or Motor Power screen and the Exciter values screen. The Generator Power or Motor Power screen is accessed from the Generator/Motor Values screen or Exciter Values screen by pressing the Generator Power or Motor Power button. This screen displays analog representations of the generator/motor active power, reactive power, and apparent power. The Exciter Values screen is accessed from the Generator/Motor Values screen or Generator/Motor Power screen by pressing the Exciter Values button. This screen displays analog representations of the excitation voltage and current. A Digital Meter button, on each analog metering screen, can be pressed to return to the DECS (digital) Metering screen.

## DECS Control

Access to the DECS Control screen is possible only when logged in with the appropriate password. When logged in, a Control button on the Main View screen provides access to the DECS Control screen illustrated in Figure 3-10. This screen has buttons for start/stop control of the DECS, accessing the Setpoint Control screen and accessing the Regulation Control screen.

### Start/Stop Control

Password-protected Start and Stop buttons provide start and stop control of the DECS controller. A red Start indicator lights when a start command is issued and a green Stop indicator lights when a stop command is issued. The Start and Stop buttons are enabled only after pressing the Log In button and entering the Level 6 password. These buttons remain enabled for the length of the Login Duration setting entered on the Screen Configuration screen.

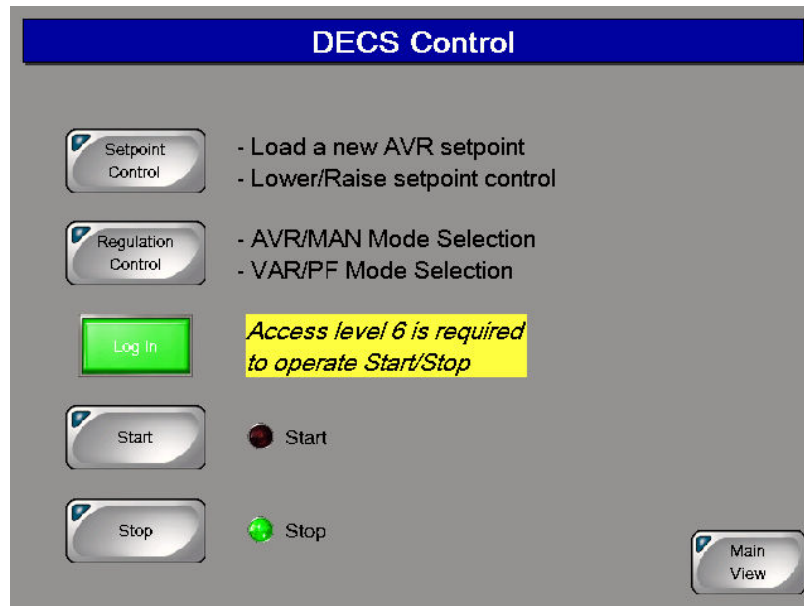

Figure 3-10. DECS Control Screen

### Setpoint Control

Pressing the Setpoint Control button accesses the Setpoint Control screen (Figure 3-11). This screen displays the DECS-400 AVR, FCR, power factor, and var setpoints and provides two methods of setpoint adjustment. The "+" and "-" buttons can be pressed to increment and decrement the active setpoint. A specific setpoint can be entered for any of the four setpoints. Pressing the New button associated with the setpoint to be changed accesses a Setpoint Adjustment screen that displays the current setpoint value along with the minimum and maximum limits for the setting. Touching the setting field area displays a numeric keypad where the new value can be entered.

The Setpoint Control screen also has system status indicators and a metering display for generator and excitation system parameters.

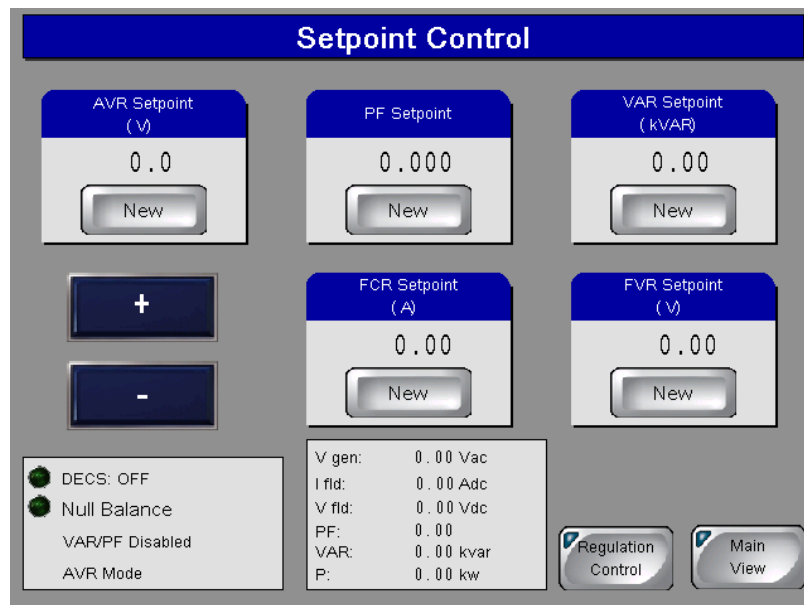

Figure 3-11. Setpoint Control Screen

## Regulation Control

Pressing the Regulation Control button accesses the Regulation Control screen (Figure 3-12). This screen enables selection of the active regulation mode. The MAN/AVR button toggles between Manual and Auto modes. When operating in AVR mode, the OFF, PF, and VAR buttons can be used to enable or disable regulation of vars or power factor. Each change to the regulation mode requires a confirmation via an accept/reject dialog box.

The Regulation Control screen also has system status indicators and a metering display for generator/motor and excitation system parameters.

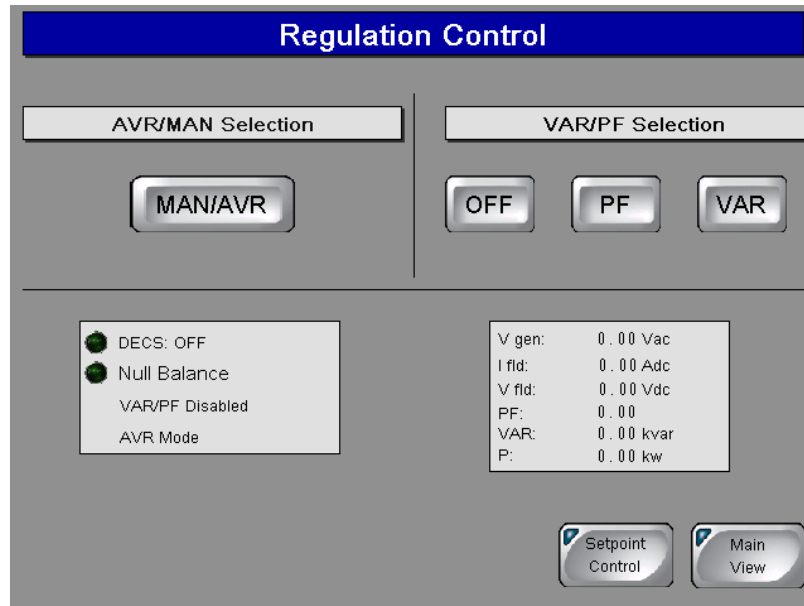

Figure 3-12. Regulation Control Screen

## Alarms and Status

Three screens annunciate the state of DECS-400 alarms, functions, limiters, and relay outputs. Depending upon the annunciation, active indicators change to amber, green, or red when active.

The Activated Alarms screen (Figure 3-13) is accessed from the Main View screen by pressing the Alarm/Status button. It can also be accessed from the DECS Status screen by pressing the Alarms button. This screen has indicators for active DECS-400 alarms, power system stabilizer status, and IDP-801 inputs and clock status. An Alarms Reset button can be pressed to clear alarm annunciations. (An alarm cannot be cleared unless the condition causing the alarm has been cleared.) Pressing the History button accesses the Alarms History screen which lists the alarms captured by the DECS-400. Buttons are provided for scrolling through the alarms list, clearing selected alarms, and clearing all listed alarms. A →USB button enables the transfer of selected alarm records to a memory device plugged into the IDP-801 USB port.

### Note

The DECS must be configured for Settings-level password access in order to enable alarm resets initiated by the IDP-801.

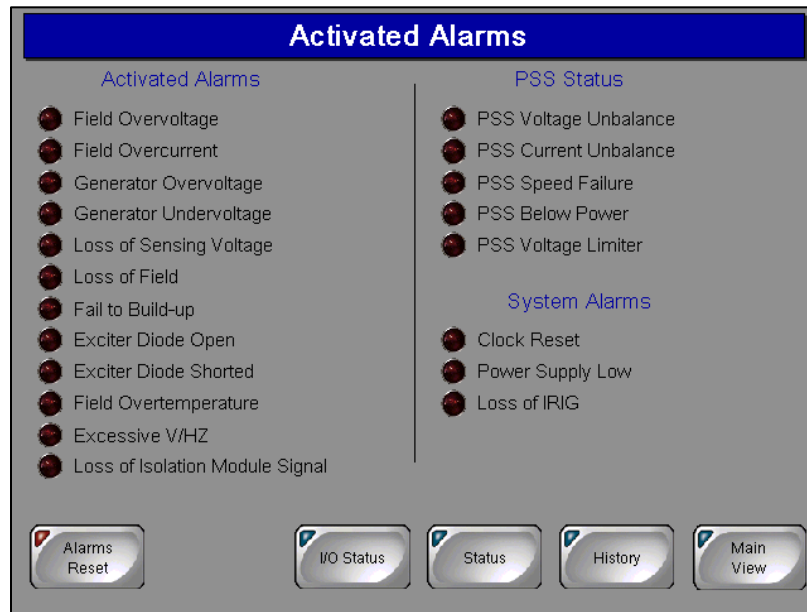

Figure 3-13. Activated Alarms Screen

The DECS I/O Status screen (Figure 3-14) is accessed from the Activated Alarms screen or the DECS Status screen by pressing the I/O Status button. This screen has indicators for the status of the DECS-400 contact inputs and relay outputs.

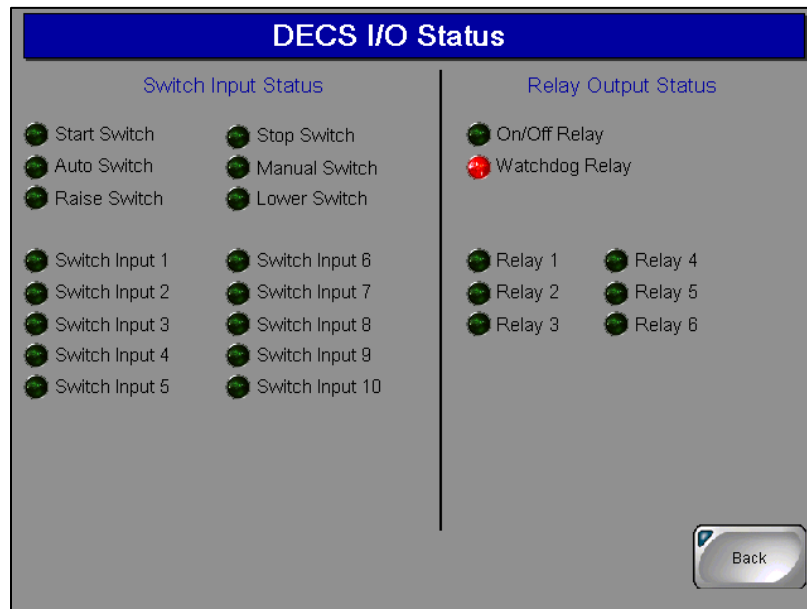

Figure 3-14. DECS I/O Status Screen

The DECS Status screen (Figure 3-15) is accessed from the Activated Alarms screen by pressing the Status button. This screen has indicators for DECS-400 operating conditions, DECS-400 setting groups, and DECS-400 limiters.

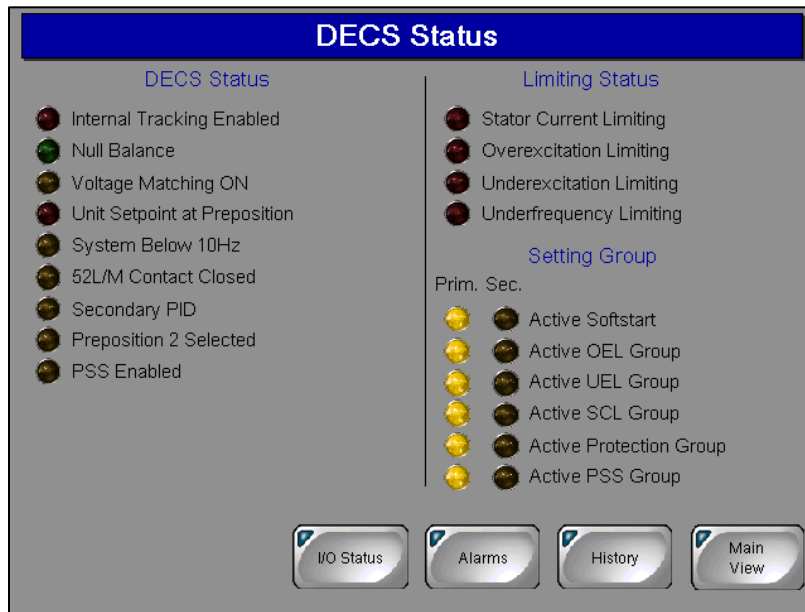

Figure 3-15. DECS Status Screen



## 4 • IDP-801-C and IDP-801-D Operation

The IDP-801-C and IDP-801-D are applied in applications using the DECS-250, DECS-250E, or DECS-250N. The IDP-801-C communicates through an RS-485 interface while the IDP-801-D communicates through an Ethernet interface. See the IDP-801 style chart for IDP-801 style definitions. This chapter describes IDP-801-C and IDP-801-D operation and screen navigation.

IDP-801 screen appearance and availability will vary according to the type of DECS used and the configuration of the DECS system (single or dual DECS and generator or motor control).

DECS and generator/motor system parameters are viewed and controlled through interactive screens displayed by the IDP-801. Screens are organized according to function. Navigation between screens and control of functions are achieved by touching “buttons” on the IDP-801 screens.

### Note

DECS-250/DECS-250N/DECS-250E firmware 1.03.00 or later is required to operate with the IDP-801.

### Configuration Screens

Two configuration screens establish DECS and IDP-801 operating modes: IDP-801 Configuration and Screen Configuration. These configuration screens are available upon initial power-up of the IDP-801. After initial configuration, these screens can be accessed through the Main View screen by entering the appropriate password.

#### IDP-801 Configuration

Upon initial power-up, the IDP-801 displays the IDP-801 Configuration screen (Figure 4-1) where your product, product configuration, and application must be selected before proceeding to other IDP-801 screens. Failure to make the proper selections may cause the IDP-801 to annunciate false alarms.

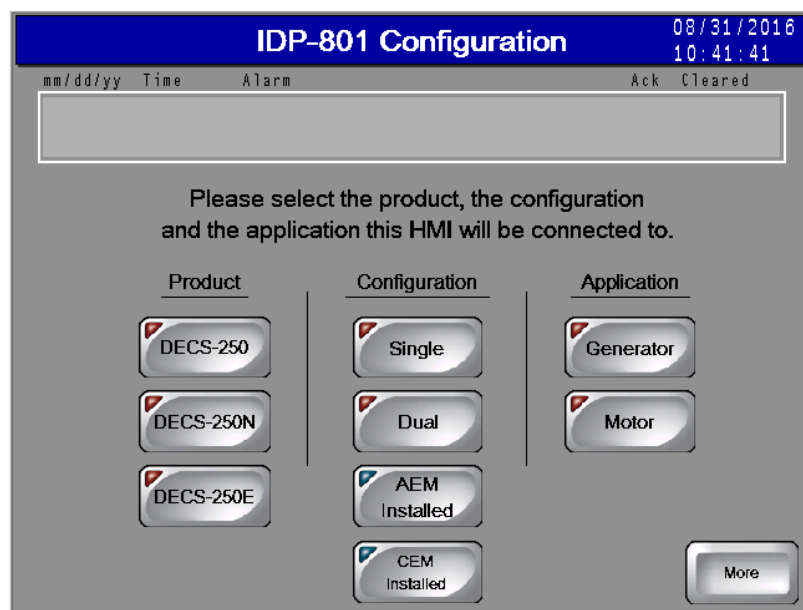

Figure 4-1. IDP-801 Configuration Screen

## Screen Configuration

Pressing the More button on the IDP-801 Configuration screen accesses the Screen Configuration screen (Figure 4-2) which enables selection of the IDP-801 date and time, and other IDP-801 operating preferences. Individual screen functions are described in the following paragraphs.

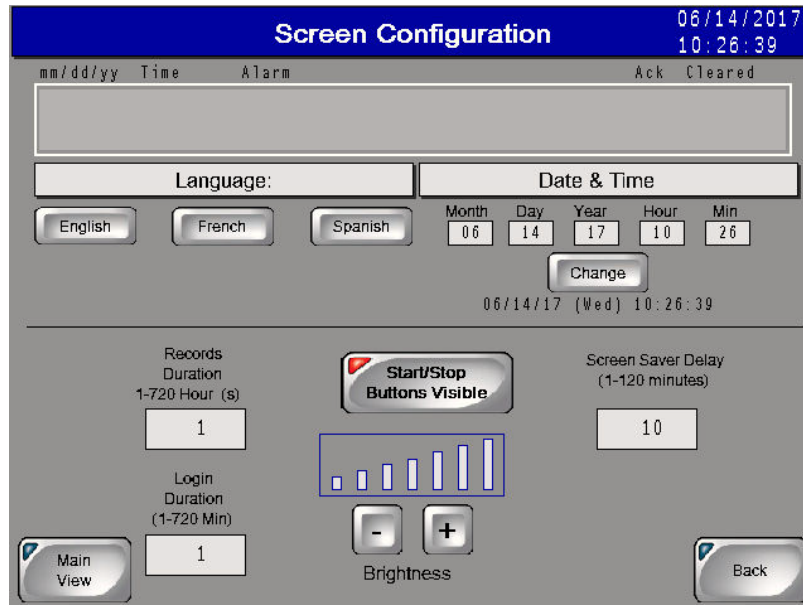

Figure 4-2. Screen Configuration

### Language

Pressing the English (Anglais or Inglés) button selects English as the IDP-801 display language. Pressing the French (Français or Francés) button selects French as the display language. Pressing the Spanish (Español or Español) button selects Spanish as the display language.

### Date and Time

The date and time of the IDP-801 must be set manually to match the date and time of the connected DECS. Enter the desired values in the date and time fields and press the Change button to save the values.

### Start/Stop Buttons Hidden/Visible

Pressing this button enables and disables visibility of the Start and Stop buttons on the DECS Control screen.

### Records Duration

Trending records saved by the IDP-801 retain up to six variables per record with each record consisting of 2,400 data points. Trending records saved by the IDP-801 can have a user-defined duration ranging from 1 hour to 720 hours (30 days). Note: requires installation of an SD/SDHC memory card.

### Login Duration

Following login, the length of time that password access is available (if no button presses occur) is limited by the value of this setting. If no button presses are received for the duration of the setting, password access is lost and the user must log in again to make changes requiring password access. Login Duration is adjustable over the range of 1 to 720 minutes (12 hours).

### Screen Saver Delay

A screensaver activates if no button presses are received at the display panel for the length of time specified by the Screen Saver Delay. A setting of 1 to 120 minutes may be entered.

### Brightness

Display panel brightness can be adjusted by pressing the “+” and “-” buttons. A bar graph above the buttons serves as a reference for adjusting the display brightness.

## **Main View Screen**

The Main View screen (Figure 4-3) serves as a gateway to the IDP-801 status and control screens. It also provides access to file transfer functions and a screen lock to enable panel cleaning. The Login button can be used to enter the appropriate password and gain access to the configuration screens.

Access to the control screens is possible only when logged into the IDP-801 with the correct password. As a result, the Control button is visible only when logged into the IDP-801.

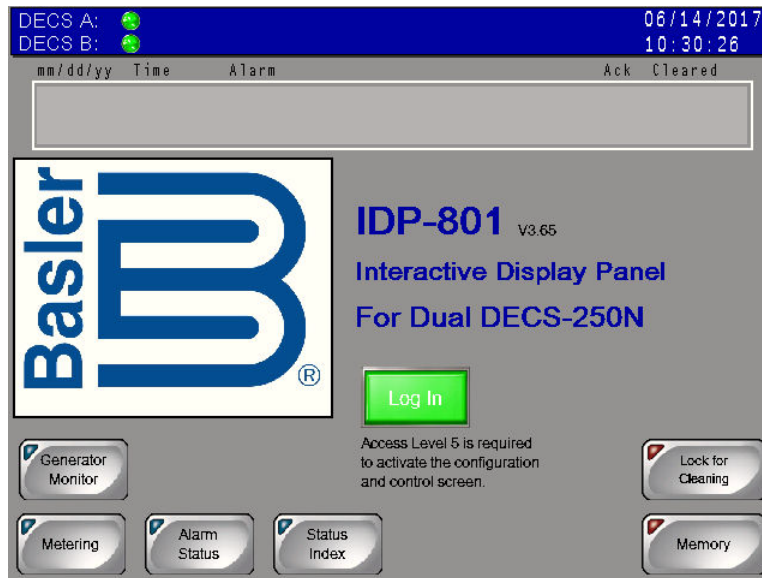

**Figure 4-3. Main View Screen**

### **IDP-801 Passwords**

Passwords protect the IDP-801 from unauthorized settings changes, control commands, and transfers offline.

Two of the passwords are used when transferring the IDP-801 offline. When taking the IDP-801 offline, the offline and system passwords are used. The IDP-801 is delivered with a system password of “4376” and an offline mode access password of “BASLER”.

A factory-default password of “idp8” gives (level 5) access to IDP-801 configuration and control functions.

A factory-default password of “decs2” gives (level 1) access to only the IDP-801 control functions.

A factory-default password of “idpx” provides start and stop control (access level 6) of the DECS through the Start and Stop buttons of the DECS Control screen.

Password access remains in effect based on display panel activity and the limit set by the Login Duration setting (Screen Configuration screen).

### **Gaining Password Access**

The following example describes the process for using a password to gain configuration and control access.

1. Press the Login button on the Main View screen.
2. Use the alphanumeric keypad to enter the appropriate password and press the Enter button. The factory-default password is IDP8 and is case-sensitive.

Once the correct password is entered, the Main View screen is displayed with a Control button that provides access to the control screens and a Configure button that provides access to the configuration screens.

## Generator/Motor Monitor

Depending upon the application selected on the IDP-801 Configuration screen, either the Generator Monitor screen or the Motor Monitor screen is accessed by pressing the Generator Monitor button or Motor Monitor button of the Main View screen. The Generator Monitor or Motor Monitor screen graphically illustrates generator/motor and excitation system status/activity. Generator and motor parameters include output voltage, output current, active (true) power, reactive power, and power factor. Excitation system parameters include field voltage, field current, and excitation on/off status. The Generator Monitor screen is shown in Figure 4-4 and the Motor Monitor screen is shown in Figure 4-5.

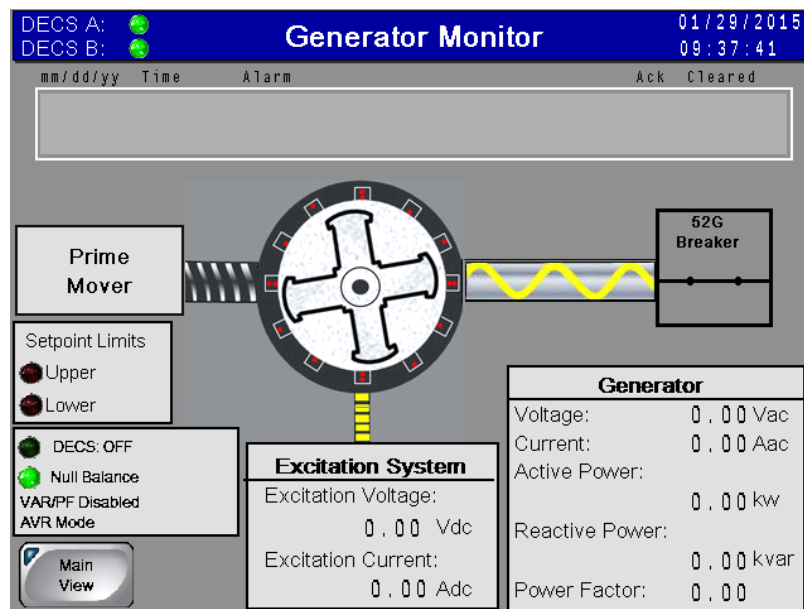

Figure 4-4. Generator Monitor Screen

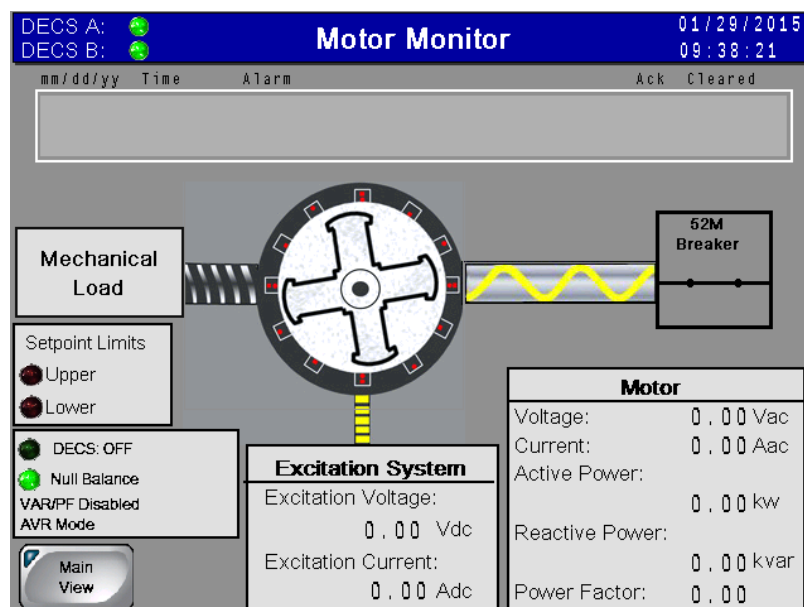

Figure 4-5. Motor Monitor Screen

## DECS Metering Screen

The DECS Metering screen (Figure 4-6) is accessed by pressing the Metering button of the Main View screen. The DECS Metering screen displays digital metering values for the generator or motor, bus, and exciter field as well as the excitation setpoint position and control values. PSS Output data is not available when the IDP-801 is configured for DECS-250E operation.

Access to the Trending, Capability Curve, Analog Meter, and DECS Status screens is also provided through the buttons at the bottom of the DECS Metering screen.

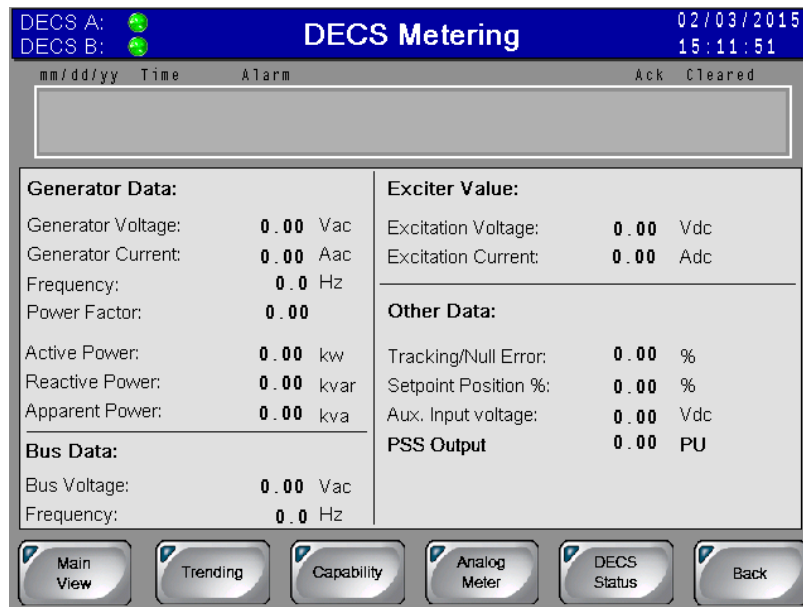

Figure 4-6. DECS Metering Screen

### Trending

The Trending screen (Figure 4-7) is accessed by pressing the Trending button of the DECS Metering screen. Several system parameters can be selected and monitored over time in an amplitude-versus-time window. Buttons on the Trending screen enable selection of the parameters to be monitored. Available parameters include generator voltage (Vgen), apparent power (kVA), true power (kW), reactive power (kvar), field voltage (Vexc), and field current (Iexc). Parameters are plotted in a color that matches the color of the parameter buttons. Pressing the History button displays additional controls and a display for manipulating the cursor position within a data plot. Pressing the USB button transfers the trending data to a connected USB memory device. Storage of trending information requires the installation of an SD/SDHC memory card.

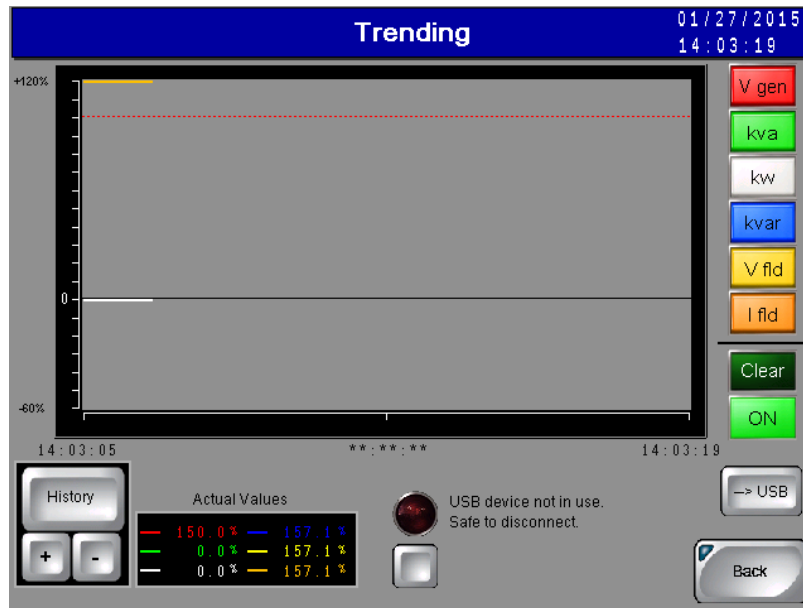

Figure 4-7. Trending Screen

## Capability

The Capability screen (Figure 4-8) is accessed by pressing the Capability button on the DECS Metering screen. By default, a horizontal curve is displayed. Pressing the Vertical Curve button selects a vertical curve orientation.

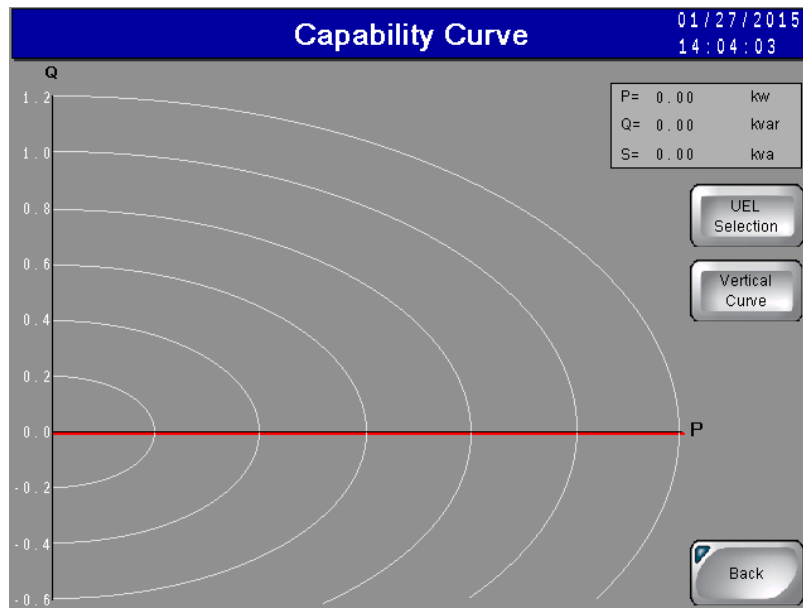

Figure 4-8. Capability Curve Screen

If a plot of the underexcitation limiter (UEL) curve is desired, the UEL Selection button can be pressed to access the UEL Curve Selection screen (Figure 4-9). Here, the internal DECS UEL curve can be selected or a customized, three-point, four-point, or five-point curve can be selected and configured. UEL curve points must be selected in BESTCOMSPi<sup>us</sup> software for an accurate representation on the IDP-801. Pressing the None button disables the display of UEL curves.

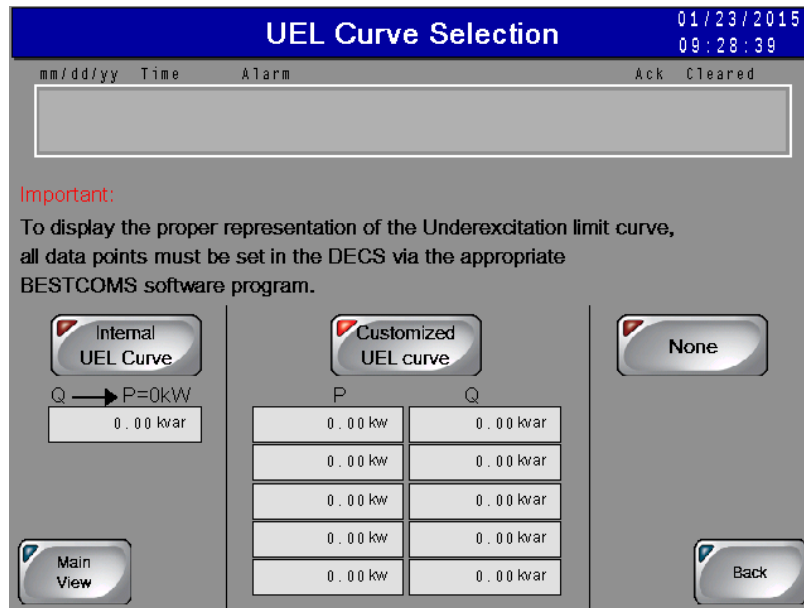

Figure 4-9. UEL Curve Selection Screen

## Analog Metering

Analog representations of the digital metering values shown on the DECS Metering screen (Figure 4-6) can be accessed by pressing the Analog Meter button. Pressing this button accesses the Generator Values or Motor Values screen (Figure 4-10) which displays analog representations of the generator/motor voltage, current, frequency, and power factor.

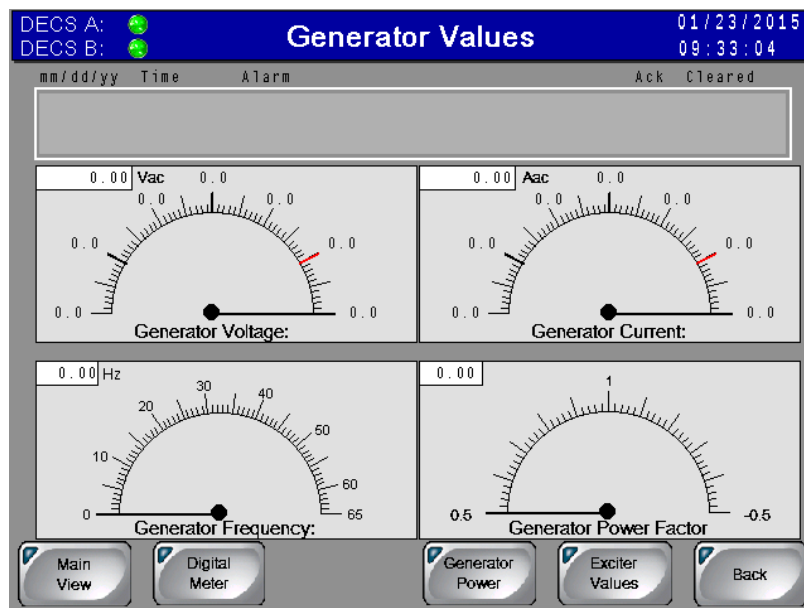

Figure 4-10. Generator Values Screen

Each analog representation displays the digital equivalent in the upper, left corner. The remaining analog metering values are divided between two screens: the Generator Power or Motor Power screen and the Exciter values screen.

The Generator Power or Motor Power screen is accessed from the Generator/Motor Values screen or Exciter Values screen by pressing the Generator Power or Motor Power button. This screen displays analog representations of the generator/motor active power, reactive power, and apparent power.

The Exciter Values screen is accessed from the Generator/Motor Values screen or Generator/Motor Power screen by pressing the Exciter Values button. This screen displays analog representations of the

excitation voltage and current. A Digital Meter button, on each analog metering screen, can be pressed to return to the DECS (digital) Metering screen.

## Status, I/O, and Alarm Screens

The Status Index screen (Figure 4-11) is accessed by pressing the Status Index button of the Main View screen. This screen provides access to alarms, alarm history, input/output status, DECS status, configurable protection, and AEM inputs.

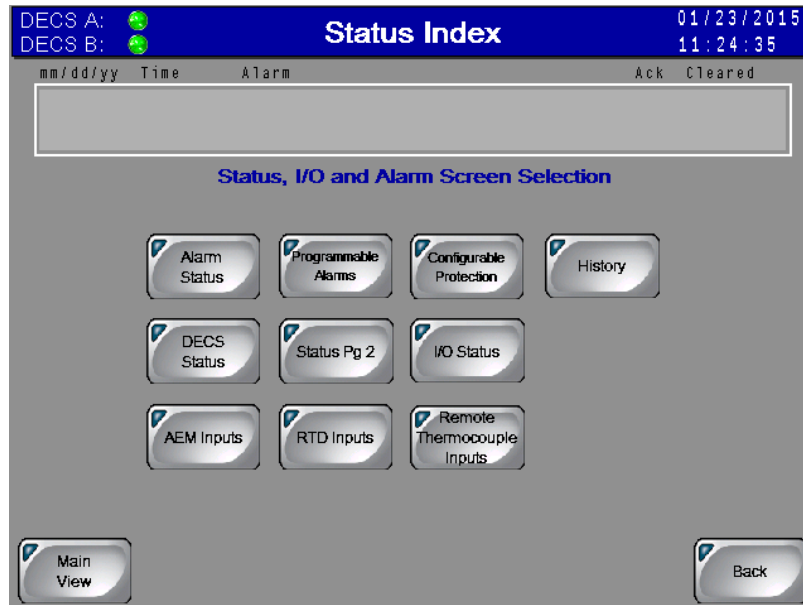

Figure 4-11. Status Index Screen

### Alarm Status

The Alarm Status screen (Figure 4-12) shows active protection alarms and general alarms. Depending upon the annunciation, active indicators change to amber, green, or red when active. An Alarms Reset button can be pressed to clear alarm annunciations. (An alarm cannot be reset unless the condition causing the alarm has been cleared.)

Bridge Over-Temperature, Bridge Over-Temperature Warning, and Pole Slip general alarms are available only when the IDP-801 is configured for DECS-250E operation.

#### Note

The DECS must be configured for Settings-level password access in order to enable alarm resets initiated by the IDP-801.

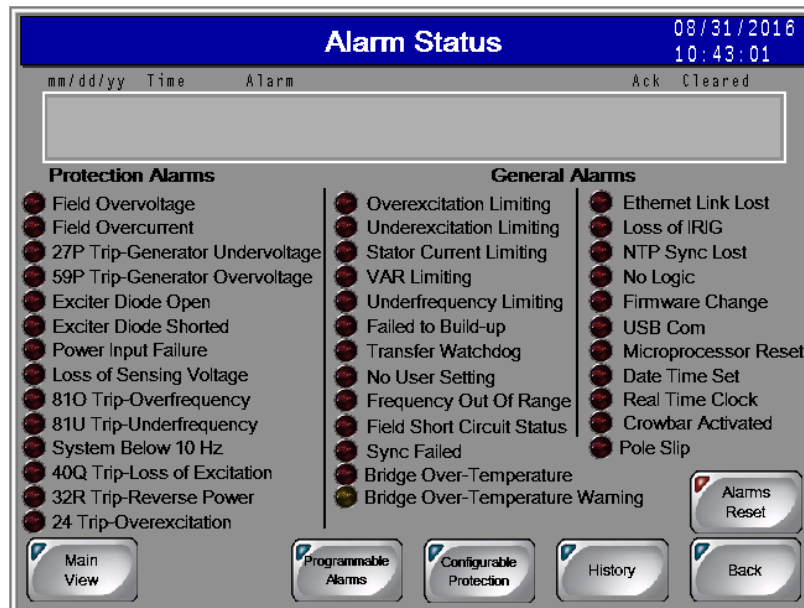

Figure 4-12. Alarm Status Screen

### Alarms History

Pressing the History button accesses the Alarms History screen (Figure 4-13) which lists the alarms captured by the DECS. Buttons are provided for scrolling through the alarms list, clearing selected alarms, and clearing all listed alarms. A →USB button enables the transfer of selected alarm records to a memory device plugged into the IDP-801 USB port.



Figure 4-13. Alarms History Screen

### **Programmable Alarms**

The Programmable Alarms screen (Figure 4-14) shows active programmable alarms. An Alarms Reset button can be pressed to clear alarm annunciations. (An alarm cannot be reset unless the condition causing the alarm has been cleared.)



Figure 4-14. Programmable Alarms Screen

### Configurable Protection

The Configurable Protection screen (Figure 4-15) shows configurable protection alarms. An alarm is active when the configurable protection threshold has been exceeded. An Alarms Reset button can be pressed to clear alarm annunciations. (An alarm cannot be reset unless the condition causing the alarm has been cleared.)

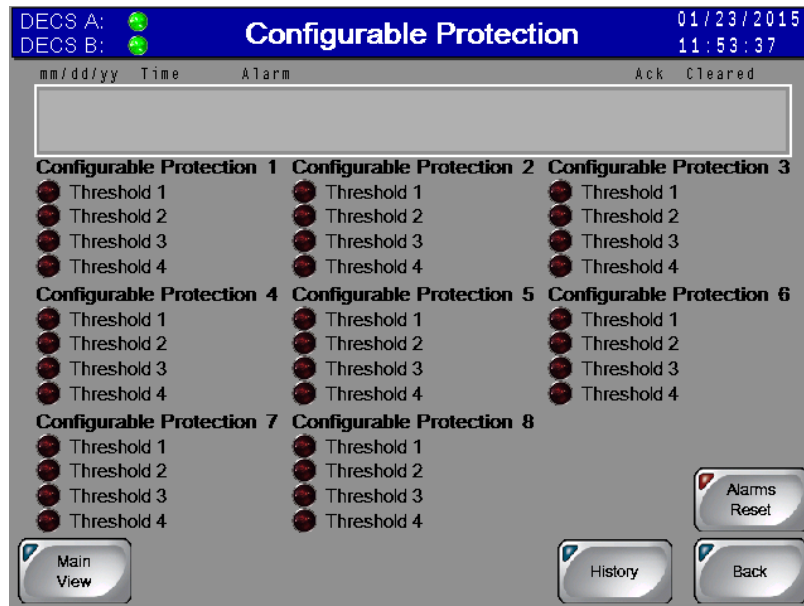

Figure 4-15. Configurable Protection Screen

### DECS Status

The Status screen (Figure 4-16) shows active DECS operating modes, status, PSS status, and limiting status.

PSS Status indicators are not available when the IDP-801 is configured for DECS-250E operation.



Figure 4-16. Status Screen

## Status Page 2

The Status Page 2 screen (Figure 4-17) shows the secondary group status, setpoint pre-position, setpoint limit alarms, and AEM alarms.

The PSS Secondary Group indicator is not available when the IDP-801 is configured for DECS-250E operation.

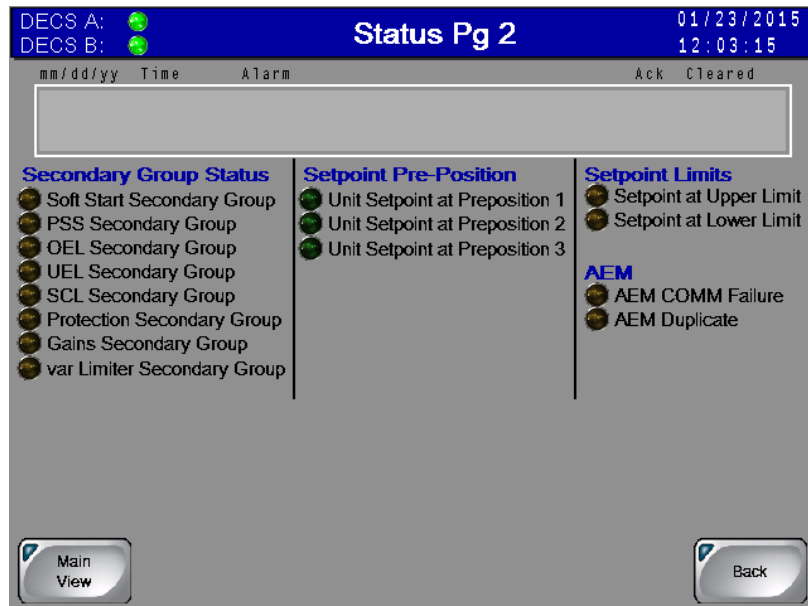

Figure 4-17. Status Page 2 Screen

## I/O Status

The I/O Status screen (Figure 4-18) has indicators for DECS contact input status and relay output status (open or closed). CEM input and output status is also shown on this screen.

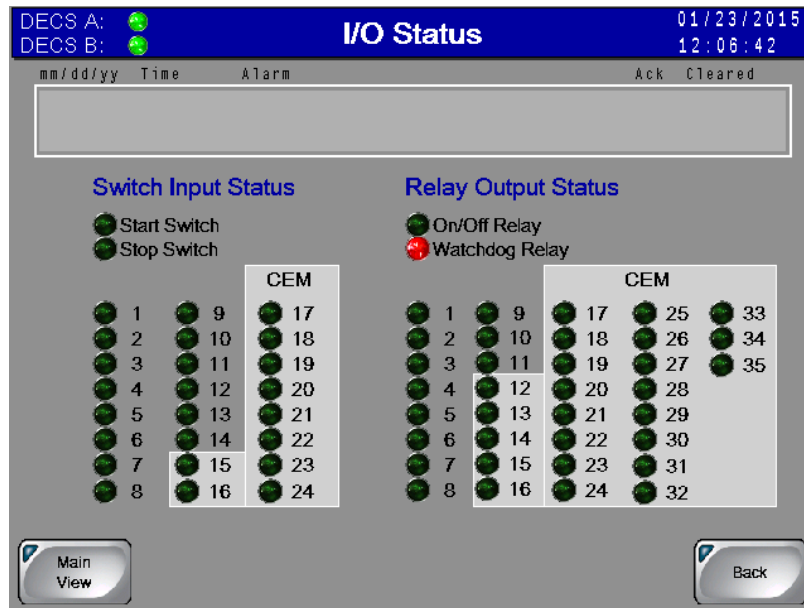

Figure 4-18. I/O Status Screen

### AEM Inputs

The AEM Inputs screen (Figure 4-19) has indicators for analog inputs and alarms.



Figure 4-19. AEM Inputs Screen

### RTD Inputs

The RTD Inputs screen (Figure 4-20) has indicators for RTD inputs and alarms.

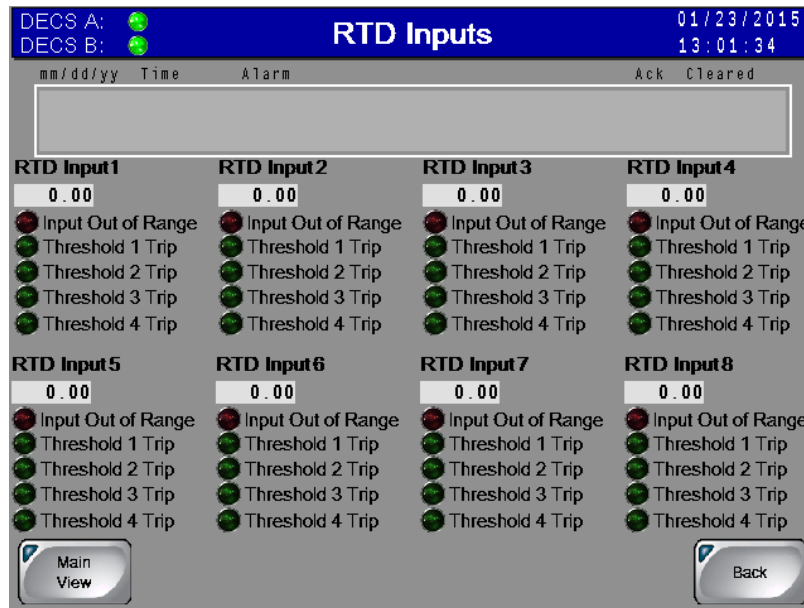

Figure 4-20. RTD Inputs Screen

### Remote Thermocouple Inputs

The Remote Thermocouple Inputs screen (Figure 4-21) has indicators for RTD inputs.

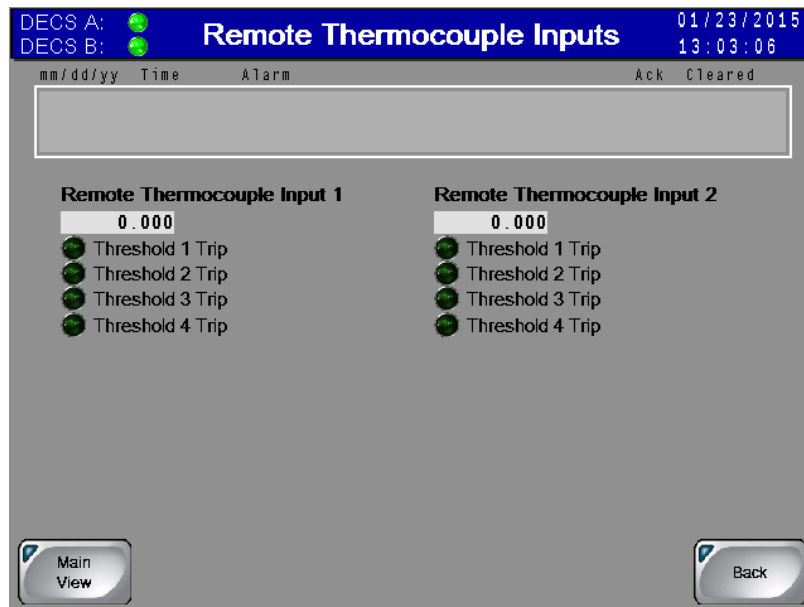

Figure 4-21. Remote Thermocouple Inputs Screen

## DECS Control

Access to the DECS Control screen is possible only when logged in with the appropriate password. When logged in, a Control button on the Main View screen provides access to the DECS Control screen illustrated in Figure 4-22. This screen has buttons for start/stop control of the DECS, accessing the Setpoint Control screen, and accessing the Regulation Control screen.

### Start/Stop Control

Password-protected Start and Stop buttons provide start and stop control of the DECS controller. A red Start indicator lights when a start command is issued and a green Stop indicator lights when a stop

command is issued. The Start and Stop buttons are enabled only after pressing the Log In button and entering the Level 6 password. These buttons remain enabled for the length of the Login Duration setting entered on the Screen Configuration screen.

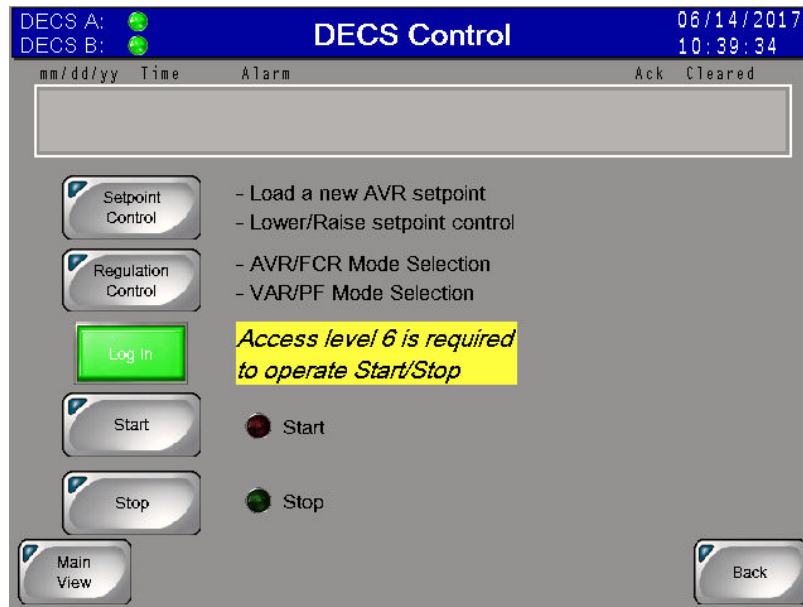

Figure 4-22. DECS Control Screen

## Setpoint Control

Pressing the Setpoint Control button accesses the Setpoint Control screen (Figure 4-23). This screen displays the DECS AVR, FCR, power factor, and var setpoints and provides two methods of setpoint adjustment. The “+” and “-” buttons can be pressed to increment and decrement the active setpoint. A specific setpoint can be entered for any of the four setpoints. Pressing the New button associated with the setpoint to be changed accesses a Setpoint Adjustment screen that displays the current setpoint value along with the minimum and maximum limits for the setting. Touching the setting field area displays a numeric keypad where the new value can be entered.

The Setpoint Control screen also has system status indicators and a metering display for generator and excitation system parameters.



Figure 4-23. Setpoint Control Screen

## Regulation Control

Pressing the Regulation Control button accesses the Regulation Control screen (Figure 4-24). This screen enables selection of the active regulation mode. The AUTO and MANUAL buttons toggle between Auto and Manual modes. When operating in AVR mode, the Off, PF, and VAR buttons can be used to enable or disable regulation of vars or power factor. Each change to the regulation mode requires a confirmation via an accept/reject dialog box.

The Regulation Control screen also has system status indicators and a metering display for generator/motor and excitation system parameters.

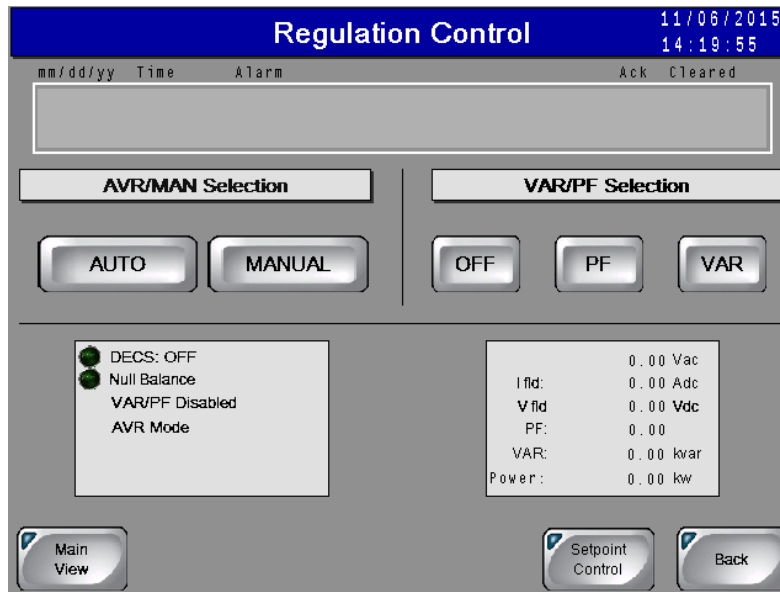

Figure 4-24. Regulation Control Screen



## 5 • IDP-801-E Operation

The IDP-801-E is applied in applications using the DECS-450. See the IDP-801 style chart for IDP-801 style definitions. This chapter describes IDP-801-E operation and screen navigation.

IDP-801 screen appearance and availability will vary according to the type of DECS used and the configuration of the DECS system (single or dual DECS).

DECS and generator system parameters are viewed and controlled through interactive screens displayed by the IDP-801. Screens are organized according to function. Navigation between screens and control of functions are achieved by touching “buttons” on the IDP-801 screens.

### Configuration Screens

Two configuration screens establish DECS and IDP-801 operating modes: IDP-801 Configuration and Screen Configuration. These configuration screens are available upon initial power-up of the IDP-801. After initial configuration, these screens can be accessed through the Main View screen by entering the appropriate password.

#### IDP-801 Configuration

Upon initial power-up, the IDP-801 displays the IDP-801 Configuration screen (Figure 5-1) where your product, product configuration, application, and communication method must be selected before proceeding to other IDP-801 screens. Failure to make the proper selections may cause the IDP-801 to annunciate false alarms.

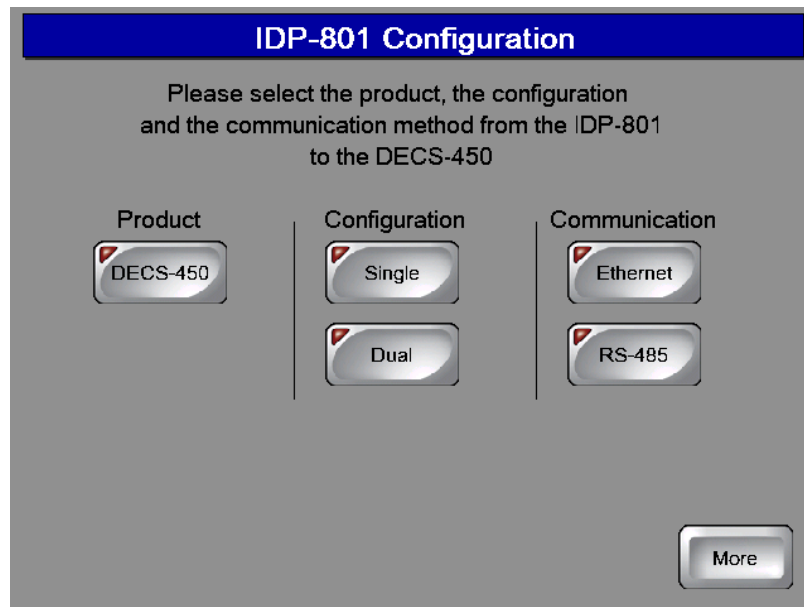

Figure 5-1. IDP-801 Configuration Screen

#### Screen Configuration

Pressing the More button on the IDP-801 Configuration screen accesses the Screen Configuration screen (Figure 5-2) which enables selection of the IDP-801 language and other operating preferences. Individual screen preferences are described in the following paragraphs.

##### Language

Pressing the English (Anglais or Inglés) button selects English as the IDP-801 display language. Pressing the French (Français or Francés) button selects French as the display language. Pressing the Spanish (Español or Español) button selects Spanish as the display language.

### Date and Time

The date and time of an IDP-801 connected to a DECS-450 is automatically synchronized with the date (month, day, and year) and time (hours and minutes) maintained by the DECS-450.

### 52L/M Input Switch Number

These buttons configure the IDP-801 to monitor the same contact inputs that the DECS-450 is monitoring for the 52L/M contact input. Pressing the Standard Logic button configures the IDP-801 to monitor contact input 3 for 52L/M contact status, which is the default assignment in standard DECS-450 logic. Pressing the Customized Logic button enables the user to configure the IDP-801 to monitor the 52L/M contact input as configured in the customized DECS-450 logic.

### Start/Stop Buttons Hidden/Visible

Pressing this button enables and disables visibility of the Start and Stop buttons on the DECS Control screen.

### Records Duration

Trending records saved by the IDP-801 retain up to six variables per record with each record consisting of 2,400 data points. Trending records saved by the IDP-801 can have a user-defined duration ranging from 1 hour to 720 hours (30 days). Note: requires installation of an SD/SDHC memory card.

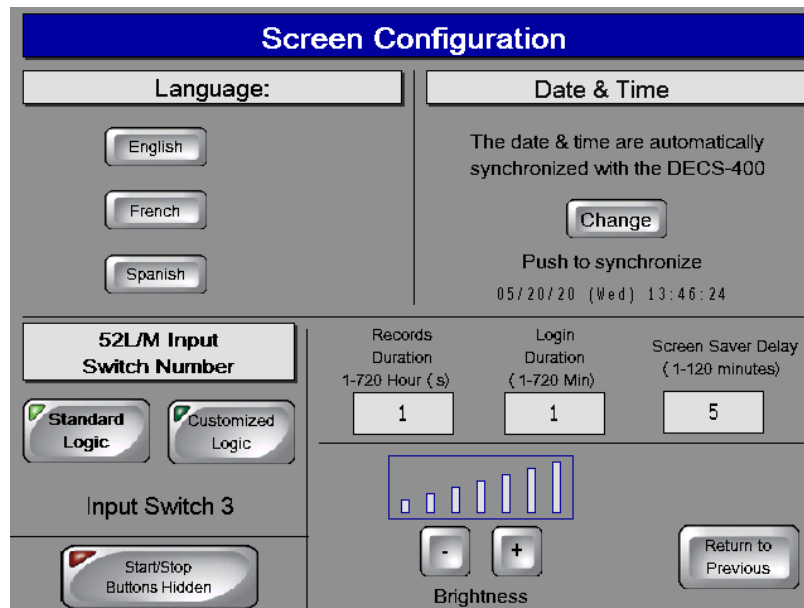

**Figure 5-2. Screen Configuration Screen**

### Login Duration

Following login, the length of time that password access is available (if no button presses occur) is limited by the value of this setting. If no button presses are received for the duration of the setting, password access is lost and the user must log in again to make changes requiring password access. Login Duration is adjustable over the range of 1 to 720 minutes (12 hours).

### Screen Saver Delay

A screensaver activates if no button presses are received at the display panel for the length of time specified by the Screen Saver Delay. A setting of 1 to 120 minutes may be entered.

### Brightness

Display panel brightness can be increased and reduced by pressing the “+” and “-” buttons. A bar graph above the buttons serves as a reference for adjusting the display brightness.

## Main View Screen

This screen (Figure 5-3) serves as a gateway to the IDP-801 status and control screens. It also provides access to file transfer functions and a screen lock to enable panel cleaning. The Login button can be used to enter the appropriate password and gain access to the configuration screens.

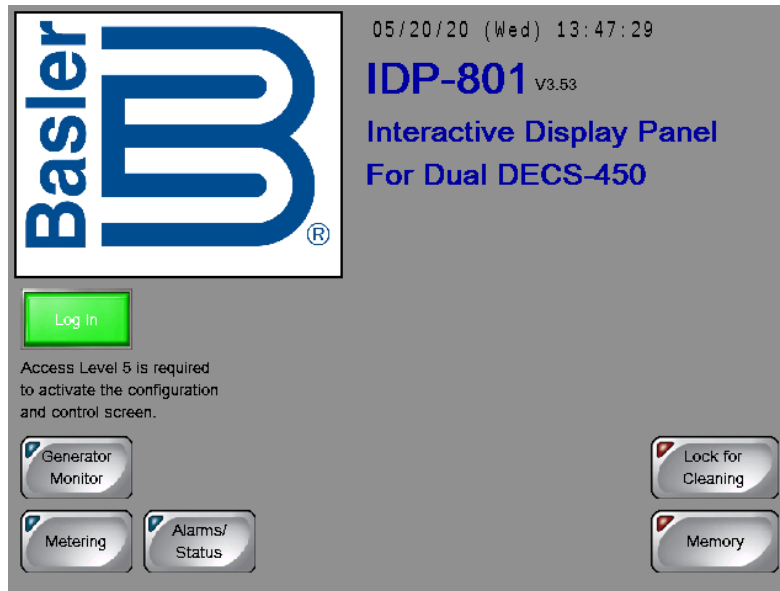

Figure 5-3. Main View Screen

Access to the Control button (and control screens) is possible only when logged into the IDP-801 with the correct password.

### IDP-801 Passwords

Passwords protect the IDP-801 from unauthorized settings changes, control commands, and transfers offline.

Two of the passwords are used when transferring the IDP-801 offline. When taking the IDP-801 offline, the offline and system passwords are used. The IDP-801 is delivered with a system password of “4376” and an offline mode access password of “BASLER”.

A factory-default password of “idp8” gives (level 5) access to IDP-801 configuration and control functions.

A factory-default password of “decs4” gives (level 1) access to only the IDP-801 control functions.

A factory-default password of “idpx” provides start and stop control (access level 6) of the DECS through the Start and Stop buttons of the DECS Control screen.

Password access remains in effect based on display panel activity and the limit set by the Login Duration setting (Screen Configuration screen).

### Gaining Password Access

The following example describes the process for using a password to gain configuration and control access.

1. Press the Login button on the Main View screen.
2. Use the alphanumeric keypad to enter the appropriate password and press the Enter button. The factory-default password is IDP8 and is case-sensitive.

Once the correct password is entered, the Main View screen is displayed with a Control button that provides access to the control screens and a Configure button that provides access to the configuration screens.

## Generator Monitor

The Generator Monitor screen is accessed by pressing the Generator Monitor button of the Main View screen. The Generator Monitor screen graphically illustrates generator and excitation system status/activity. Generator parameters include output voltage, output current, active (true) power, reactive power, and power factor. Excitation system parameters include field voltage, field current, and excitation on/off status. The Generator Monitor screen is shown in Figure 5-4.

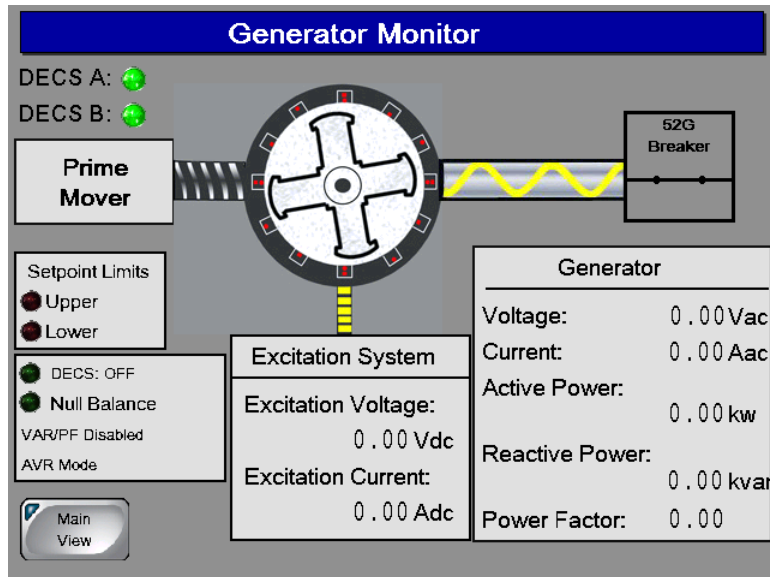

Figure 5-4. Generator Monitor Screen

## DECS Metering Screen

Access the DECS Metering screen (Figure 5-5) by pressing the Metering button of the Main View screen. The DECS Metering screen displays digital metering values for the generator or motor, bus, and exciter field as well as the excitation setpoint position and control values.

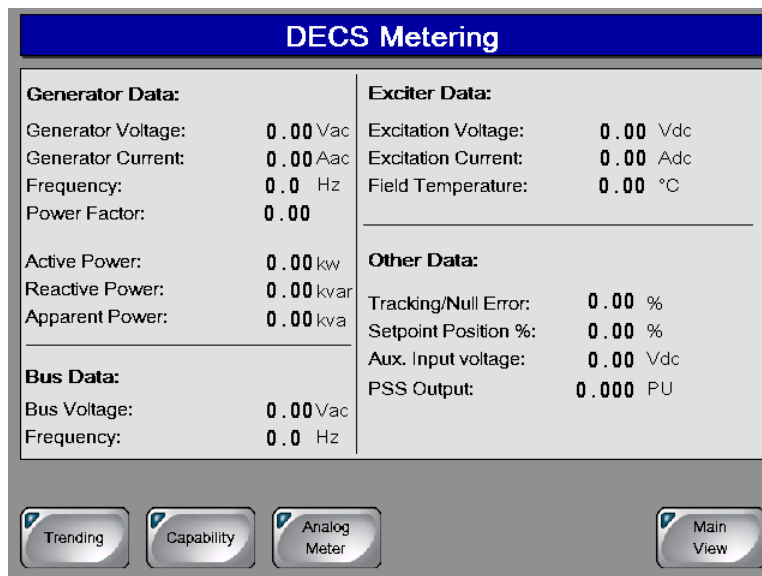

Figure 5-5. DECS Metering Screen

## Analog Metering

Pressing the Analog Meter button accesses the analog representations of the digital values displayed on the DECS Metering screen. Analog metering values are divided among three screens accessed through buttons labeled Generator Values, Generator Power, and Exciter Values. Each parameter is represented by an analog meter along with the digital version of the metered value.

## Trending

Access to the Trending and Capability Curve screens is also provided through the Trending and Capability buttons on the DECS Metering screen.

The Trending screen (Figure 5-6) is accessed by pressing the Trending button of the DECS Metering screen. Several system parameters can be selected and monitored over time in an amplitude-versus-time window. Buttons on the Trending screen enable selection of the parameters to be monitored. Available parameters include generator voltage (Vgen), apparent power (kVA), true power (kW), reactive power (kvar), field voltage (Vfld), and field current (Ifld). Parameters are plotted in a color that matches the color of the parameter buttons. Pressing the History button displays additional controls and a display for manipulating the cursor position within a data plot. Pressing the USB button accesses the Memory Transfer screen where the data from a trending plot can be transferred to USB memory device. Storage of trending information requires the installation of an SD/SDHC memory card.

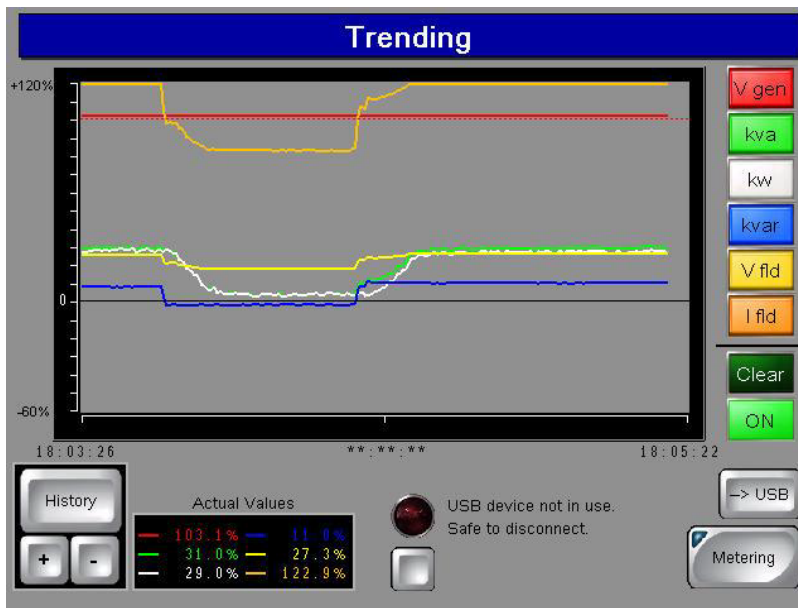

Figure 5-6. Trending Screen

## Capability

Access the Capability screen (Figure 5-7) by pressing the Capability button on the DECS Metering screen. By default, a horizontal curve is displayed. Pressing the Vertical Curve button selects a vertical curve orientation.

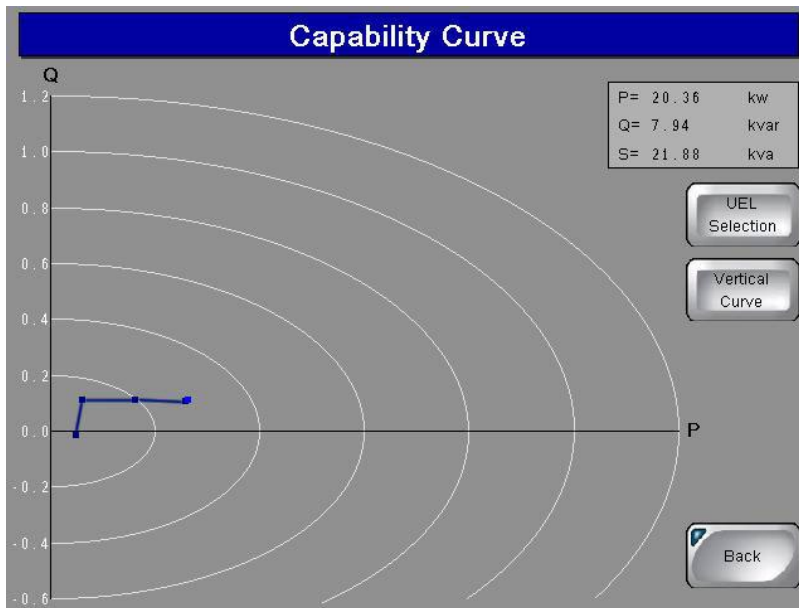

Figure 5-7. Capability Curve Screen

If a plot of the underexcitation limiter (UEL) curves is desired, the Internal UEL Curve button can be pressed to access the UEL Curve Selection screen (Figure 5-8). Here, the internal DECS UEL curve can be selected or a customized, three-, four-, or five-point curve can be selected and configured. UEL curve points must be selected in the DECS BESTCOMS*Plus*® software for an accurate representation on the IDP-801. Pressing the None button disables the display of UEL curves.

Figure 5-8. UEL Curve Selection Screen

## DECS Analog Metering

Analog representations of the digital metering values shown on the DECS Metering screen (Figure 5-5) can be accessed by pressing the Analog Meter button. Pressing this button accesses the Generator Values screen which displays analog representations of the generator voltage, current, frequency, and power factor. Each analog representation displays the digital equivalent in the upper, left corner. The remaining analog metering values are divided between two screens: the Generator Power screen and the Exciter values screen. The Generator Power screen is accessed from the Generator Values screen or Exciter Values screen by pressing the Generator Power button. This screen displays analog

representations of the generator active power, reactive power, and apparent power. The Exciter Values screen is accessed from the Generator Values screen or Generator Power screen by pressing the Exciter Values button. This screen displays analog representations of the excitation voltage and current. A Digital Meter button, on each analog metering screen, can be pressed to return to the DECS (digital) Metering screen.

## DECS Control

Access to the DECS Control screen is possible only when logged in with the appropriate password. When logged in, a Control button on the Main View screen provides access to the DECS Control screen illustrated in Figure 5-9. This screen has buttons for start/stop control of the DECS, accessing the Setpoint Control screen and accessing the Regulation Control screen.

### Start/Stop Control

Password-protected Start and Stop buttons provide start and stop control of the DECS controller. A red Start indicator lights when a start command is issued and a green Stop indicator lights when a stop command is issued. The Start and Stop buttons are enabled only after pressing the Log In button and entering the Level 6 password. These buttons remain enabled for the length of the Login Duration setting entered on the Screen Configuration screen.

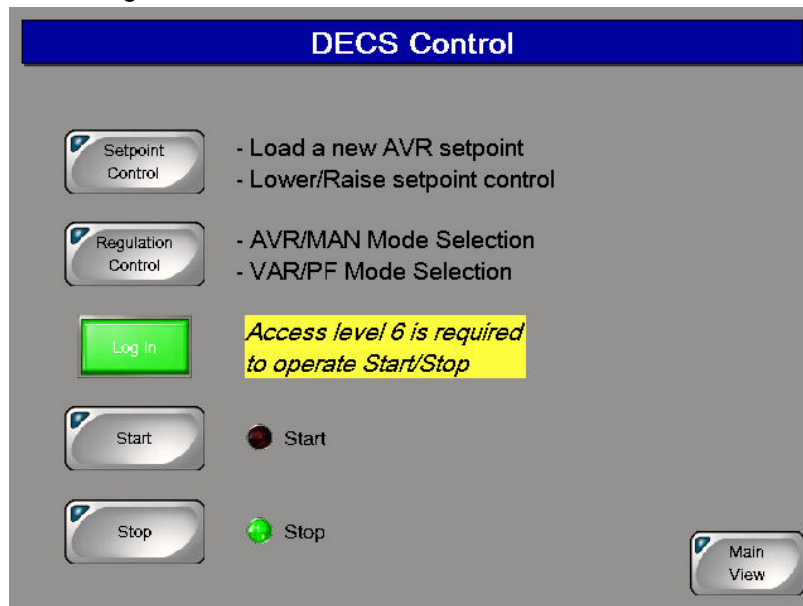

Figure 5-9. DECS Control Screen

### Setpoint Control

Pressing the Setpoint Control button accesses the Setpoint Control screen (Figure 5-10). This screen displays the DECS-450 AVR, FCR, power factor, and var setpoints and provides two methods of setpoint adjustment. The “+” and “-” buttons can be pressed to increment and decrement the active setpoint. A specific setpoint can be entered for any of the four setpoints. Pressing the New button associated with the setpoint to be changed accesses a Setpoint Adjustment screen that displays the current setpoint value along with the minimum and maximum limits for the setting. Touching the setting field area displays a numeric keypad where the new value can be entered.

The Setpoint Control screen also has system status indicators and a metering display for generator and excitation system parameters.

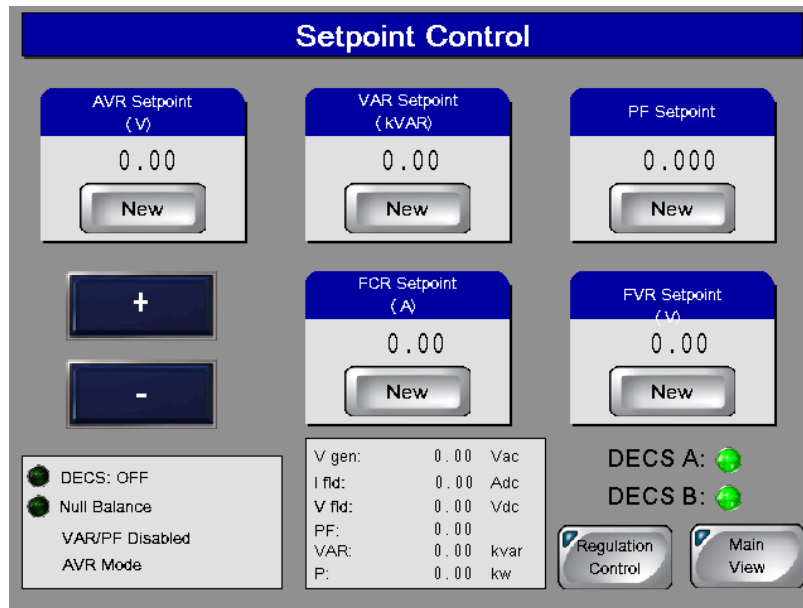

Figure 5-10. Setpoint Control Screen

### Regulation Control

Pressing the Regulation Control button accesses the Regulation Control screen (Figure 5-11). This screen enables selection of the active regulation mode. The MAN/AVR button toggles between Manual and Auto modes. When operating in AVR mode, the OFF, PF, and VAR buttons can be used to enable or disable regulation of vars or power factor. Each change to the regulation mode requires a confirmation via an accept/reject dialog box.

The Regulation Control screen also has system status indicators and a metering display for generator/motor and excitation system parameters.

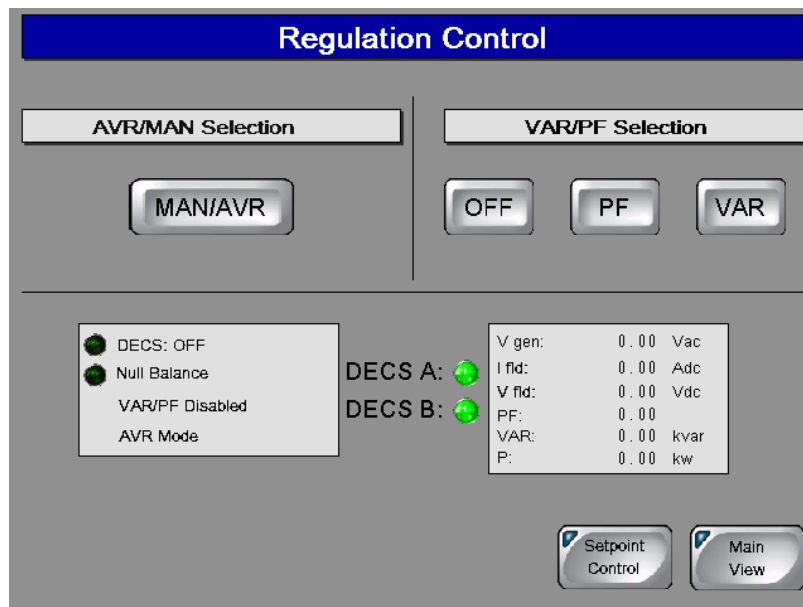

Figure 5-11. Regulation Control Screen

## Alarms and Status

Three screens annunciate the state of DECS-450 alarms, functions, limiters, and relay outputs. Depending upon the annunciation, active indicators change to amber, green, or red when active.

The Activated Alarms screen (Figure 5-12) is accessed from the Main View screen by pressing the Alarm/Status button. It can also be accessed from the DECS Status screen by pressing the Alarms button. This screen has indicators for active DECS-450 alarms, power system stabilizer status, and IDP-801 inputs and clock status. An Alarms Reset button can be pressed to clear alarm annunciations. (An alarm cannot be cleared unless the condition causing the alarm has been cleared.) Pressing the History button accesses the Alarms History screen which lists the alarms captured by the DECS-450. Buttons are provided for scrolling through the alarms list, clearing selected alarms, and clearing all listed alarms. A →USB button enables the transfer of selected alarm records to a memory device plugged into the IDP-801 USB port.

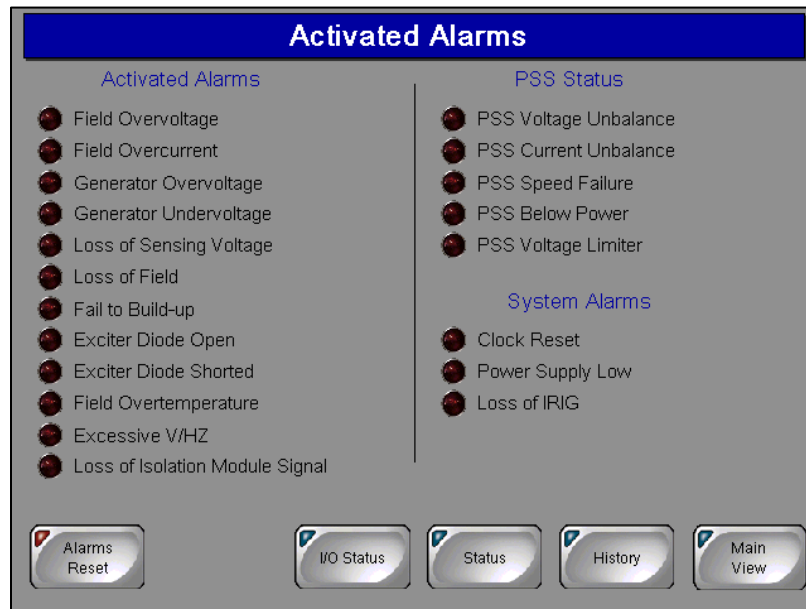

Figure 5-12. Activated Alarms Screen

### Note

The DECS must be configured for Settings-level password access in order to enable alarm resets initiated by the IDP-801.

The DECS I/O Status screen (Figure 5-13) is accessed from the Activated Alarms screen or the DECS Status screen by pressing the I/O Status button. This screen has indicators for the status of the DECS-450 contact inputs and relay outputs.

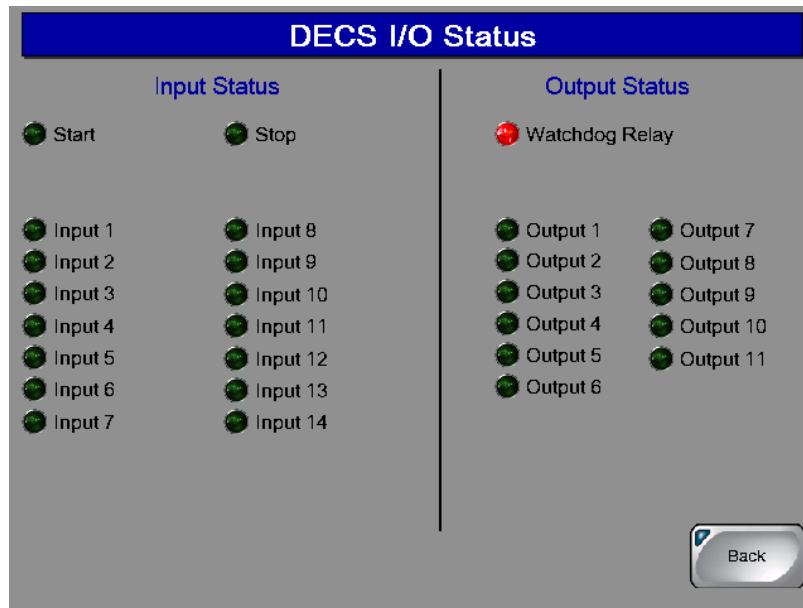

Figure 5-13. DECS I/O Status Screen

The DECS Status screen (Figure 5-14) is accessed from the Activated Alarms screen by pressing the Status button. This screen has indicators for DECS-450 operating conditions, DECS-450 setting groups, and DECS-450 limiters.

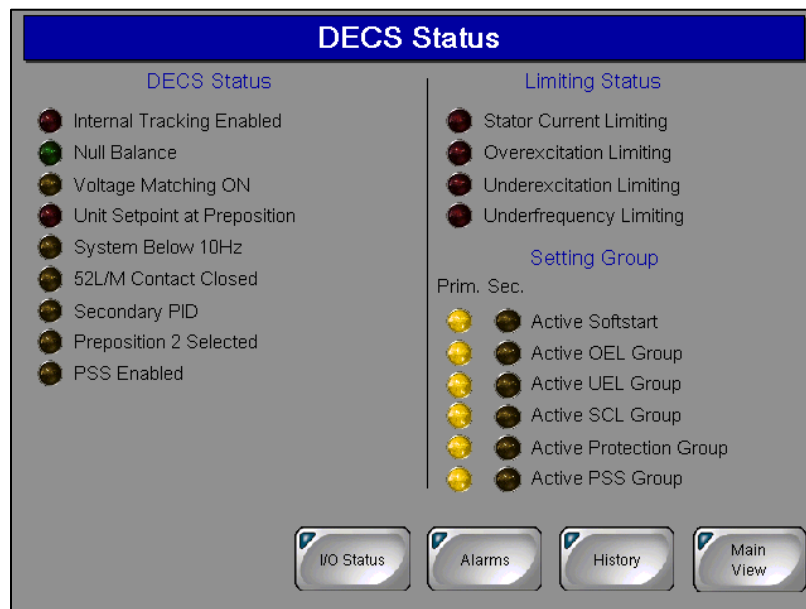

Figure 5-14. DECS Status Screen

## 6 • Modbus® Communication

When DECS-400 or DECS-450 controllers are connected (through an Ethernet switch or hub) to an Ethernet network, all Modbus registers of each DECS-400 or DECS-450 can be interrogated directly through the LAN. Likewise, when a DECS-250, DECS-250E, or DECS-250N is connected to an Ethernet network through an IDP-801-D, all Modbus registers of the DECS can be interrogated directly through the LAN. For a complete list of DECS Modbus holding register assignments, refer to the appropriate DECS instruction manual.

The Modbus holding registers of a DECS-250/DECS-250N/DECS-250E can be interrogated through the IDP-801-C. The amount of information (registers) available through the IDP-801-C is limited to three categories: metering, operating modes, and setpoints.

This chapter lists the assignments and descriptions of the Modbus holding registers accessible through the IDP-801-C (DECS-250, DECS-250N, and DECS-250E). The following conventions apply in the register tables. In the Access column, “R” represents read access and “W” represents write access. Data formats are described as follows.

### Data Type UI6

Corresponding Built-In Data Type: UINT16, unsigned short integer

Data Range: 0 to 65,535

Data Size in Bytes: 2

Total Number of Modbus Registers to Hold Data: 1

### Data Type R32\_23

Corresponding Built-In Data Type: FLOAT, floating point number

Data Range: from approximately  $8.43 \times 10^{-37}$  to  $3.38 \times 10^{38}$

Data Size in Bytes: 4

Total Number of Modbus Registers to Hold Data: 2

### Caution

This product contains one or more *nonvolatile memory* devices. Nonvolatile memory is used to store information (such as settings) that needs to be preserved when the product is power-cycled or otherwise restarted. Established nonvolatile memory technologies have a physical limit on the number of times they can be erased and written. During product application, consideration should be given to communications, logic, and other factors that may cause frequent/repeated writes of settings or other information that is retained by the product. Applications that result in such frequent/repeated writes may reduce the useable product life and result in loss of information and/or product inoperability.

## ***IDP-801 Register Table***

Data transmitted via Modbus is identified by holding registers. Table 6-1 lists the holding register assignments and descriptions for the IDP-801-C. In the Access column of Table 6-1, “W-” indicates write-access.

**Table 6-1. IDP-801 Register Table**

Register	Data Description	Access	Data Format
47715	New FCR setpoint To load this new setpoint in the AVR, it is necessary to pass register 47723 at 1	W-	R32_23
47717	New AVR setpoint To load this new setpoint in the AVR, it is necessary to pass register 47724 at 1	W-	R32_23
47719	New VAR setpoint To load this new setpoint in the AVR, it is necessary to pass register 47725 at 1	W-	R32_23
47721	New PF setpoint To load this new setpoint in the AVR, it is necessary to pass register 47726 at 1	W-	R32_23
47723	Load new FCR setpoint to AVR 0= No change ; 1=change	W-	UI16
47724	Load new AVR setpoint to AVR 0= No change ; 1=change	W-	UI16
47725	Load new VAR setpoint to AVR 0= No change ; 1=change	W-	UI16
47726	Load new PF setpoint to AVR 0= No change ; 1=change	W-	UI16
47727	Virtual toggle switch for changing control mode from comm. port between AVR and FCR: 0 = no change / 1 = change state. Holding register 47573 contains Control mode status.	W-	UI16
47728	Switch for changing operating mode via comm. port to one of three modes. 0=OFF / 1=PF / 2=var. Holding register 47571 contains Operating mode status. To change the operating mode in the AVR, it is necessary to pass the register 47729 at 1	W-	UI16
47729	Load new operation mode to the AVR 0= No change ; 1=change	W-	UI16
47730	Raise input enable status from comm. port: 0 = Off / 1 = On	W-	UI16
47731	Lower input enable status from comm. port: 0 = Off / 1 = On	W-	UI16

## ***DECS-250, DECS-250N, and DECS-250E Register Tables***

Three categories of DECS-250, DECS-250N, and DECS-250E information can be accessed through the IDP-801 using the Modbus communication protocol: C2 (metering), C5 (operating modes), and C6 (setpoints).

### **DECS-250, DECS-250N, and DECS-250E Metering Information Category C2**

Category C2 holding register assignments and descriptions are listed in Table 6-2.

**Table 6-2. DECS-250/DECS-250N/DECS-250E Metering Information Category C2**

Register	Data Description	Access	Data Format
47257-58	Average of the 3 rms line-to-line voltages	R-	R32_23
47259-60	Phase B generator current in amps	R-	R32_23
47261-62	Generator apparent power in kVA	R-	R32_23
47263-64	Generator real power in kW	R-	R32_23

Register	Data Description	Access	Data Format
47265-66	Generator reactive power in kvar	R-	R32_23
47267-68	Power factor	R-	R32_23
47269-70	Generator frequency in hertz	R-	R32_23
47271-72	Bus frequency in Hz	R-	R32_23
47273-74	RMS bus voltage in volts	R-	R32_23
47275-76	Field voltage in volts	R-	R32_23
47277-78	Field current in amps	R-	R32_23
47283-84	Auxiliary input in volts (PSS input for DECS-250 and DECS-250N)	R-	R32_23
47287-88	Null balance (tracking error) in percent	R-	R32_23
47295	Status of the Front panel LEDs (bit flags, where 0=off, 1=on for all LEDs except Null Balance and Internal Tracking which are reversed): b0=Null Balance, b1=Tracking, b2=Pre-position, b3=Upper Limit, b4=Lower Limit, b5=Edit, b6-b15=unassigned	R-	UI16
47296	Voltage matching status: 0=off / 1=on	R-	UI16
47297	Protection status bit flags (0=clear, 1=condition present): b0=field overvoltage, b1=field overcurrent, b2=gen. Undervoltage, b3=gen. overvoltage, b4=underfrequency, b5=in OEL, b6=in UEL, b7=in FCR mode, b8=loss of sensing voltage, b9=setpoint at lower limit, b10=setpoint at upper limit, b11=gen. failed to build up, b12=gen. below 10Hz, b13=unassigned, b14=exciter diode open, b15=exciter diode shorted.	R-	UI16
47300-01	The active operating setpoint expressed as a percent of its present adjustment range.	R-	R32_23
47302	The state of some contact inputs: b0 = 52JK, b1 = 52LM, b2 = Automatic transfer, b3 = External Tracking Enable	R-	UI16
47303	Annunciation status bit flags (0=clear, 1=annunciation present): b0=field overvoltage, b1=field overcurrent, b2=gen. undervoltage, b3=gen. overvoltage, b4=underfrequency, b5=in OEL, b6=in UEL, b7=in FCR mode, b8=loss of sensing voltage, b9=setpoint at lower limit, b10=setpoint at upper limit, b11=gen. failed to build up, b12=gen. below 10Hz, b13=unassigned, b14=exciter diode open, b15=exciter diode shorted..	R-	UI16
47306	Protection status bit flags (0 = clear, 1 = condition present) b0 = loss of field, b1 = in SCL, b2 – b15 are unassigned	R-	UI16
47307	Annunciation status bit flags (0 = clear, 1 = condition present) b0 = loss of field, b1 = in SCL, b2 – b15 are unassigned	R-	UI16

### DECS-250, DECS-250N, and DECS-250E Operating Mode Information Category C5

Category CT holding register assignments and descriptions are listed in Table 6-3.

**Table 6-3. DECS-250/DECS-250N/DECS-250E Operating Mode Information Category C5**

Register	Data Description	Access	Data Format
47561	Unit mode virtual toggle. Any entry of '1' toggles through Stop, Start modes.	RW	UI16
47571	Operating mode: 0 = Off / 1 = PF Control / 2 = var Control	R-	UI16
47572	Unit mode status: 0 = Stop / 1 = Start	R-	UI16
47573	Control mode status: 1 = FCR / 2 = AVR	R-	UI16

## DECS-250, DECS-250N, and DECS-250E Setpoints Information Category C6

Category C6 holding register assignments and descriptions are listed in Table 6-4.

**Table 6-4. DECS-250/DECS-250N/DECS-250E Setpoints Information Category C6**

Register	Data Description	Access	Data Format
47621-22	FCR (field current regulator) mode setpoint; adjustment range is determined by registers (47699-700) and (47707-08)	RW	R32_23
47623-24	AVR (automatic voltage regulator) mode setpoint; adjustment range is determined by registers (47701-02) and (47709-10)	RW	R32_23
47625-26	Var mode setpoint (in kvar); adjustment range is determined by registers (47703-04) and (47711-12)	RW	R32_23
47627-28	PF mode setpoint; adjustment range is determined by registers (47705-06) and (47713-14)	RW	R32_23
47699-700	FCR minimum setpoint (in amps) = % of nominal x rated field current:(regs. 47655-56) x (regs. 47529-30) / 100	R-	R32_23
47701-02	AVR minimum setpoint (in volts) = % of nominal x rated gen. voltage:(regs. 47657-58) x (regs. 47525-26) / 100	R-	R32_23
47703-04	Var minimum setpoint (in kvar) = % of nominal x rated generator VA:(regs. 47659-60) x rated VA / 100	R-	R32_23
47705-06	PF minimum setpoint = registers 47661-62	R-	R32_23
47707-08	FCR maximum setpoint (in amps) = % of nominal x rated field current:(regs. 47663-64) x (regs. 47529-30) / 100	R-	R32_23
47709-10	AVR maximum setpoint (in volts) = % of nominal x rated gen. Voltage:(regs. 47665-66) x (regs. 47525-26) / 100	R-	R32_23
47711-12	Var maximum setpoint (in kvar) = % of nominal x rated gen. VA:(regs. 47667-68) x rated VA / 100	R-	R32_23
47713-14	PF maximum setpoint = registers 47669-70	R-	R32_23

## DECS-400 and DECS-450 Register Tables

All Modbus registers of the DECS-400 and DECS-450 can be interrogated directly through the connected LAN. Refer to the DECS-400 or DECS-450 instruction manual for the available register assignments and descriptions.

## 7 • Mounting

IDP-801 mounting consists of selecting a suitable mounting location, cutting the panel opening, and securing the display to the panel.

### Warning!

The control panel/equipment enclosure where the IDP-801 will be installed must be removed from service and all related operating and control power de-energized before proceeding with IDP-801 installation.

### ***Mounting Considerations***

The IDP-801 is intended for mounting in a cutout on a vertical panel in an environment where the ambient temperature does not exceed the temperature range of 0 to 50°C (32 to 122°F). Observe the following considerations and guidelines when preparing to mount the IDP-801.

#### **Location and Environmental Considerations**

The IDP-801 is intended for mounting in a vertical panel. If mounting the IDP-801 in a slanted panel, the panel should not deviate more than thirty degrees from vertical. If the panel slants more than thirty degrees, you must ensure that the ambient temperature surrounding the IDP-801 does not exceed 40°C (104°F). This may require the use of external cooling equipment (such as a fan or air conditioner). To enhance ventilation and maintenance, the IDP-801 should be installed no closer than 4 inches (10 centimeters) from adjacent equipment. Heat created by nearby equipment must not cause the ambient temperature surrounding the IDP-801 to exceed its maximum operating temperature.

### Caution

Do not install or store the IDP-801 where it is exposed to sunlight. The heat and ultraviolet rays from sun exposure can cause the touch-screen to deteriorate, shortening the life of the IDP-801.

#### **Mounting Panel Thickness**

The IDP-801 can be mounted on a panel with a thickness no less than 0.06 inches (1.6 millimeters) and no more than 0.39 inches (10.0 millimeters).

#### ***Cutting the Panel Opening***

Cut an opening in the mounting panel that is 8.05 inches (205 millimeters) wide and 6.28 inches (160 millimeters) high. Figure 7-1 illustrates the panel cutting dimensions.

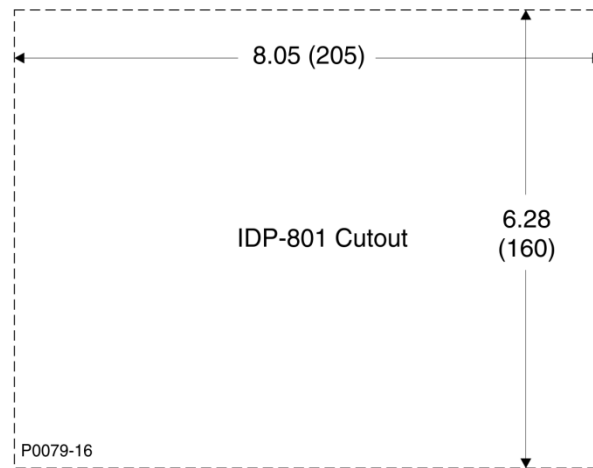

**Figure 7-1. IDP-801 Panel Cutting Dimensions**

## Securing the IDP-801

The IDP-801 is secured to a panel with four hook-and-screw fasteners. The hook of each fastener is inserted in one of four display panel insertion slots (Figure 7-2) and the fastener screw is tightened against the mounting panel (Figure 7-3).

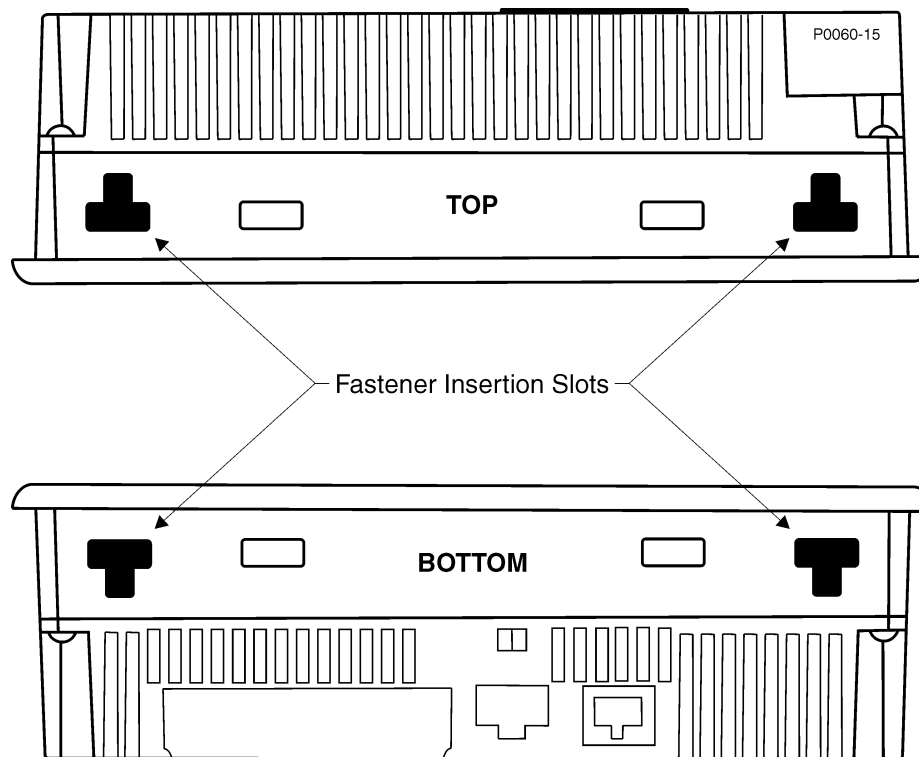

**NOTE**

The hook of each fastener must be inserted securely into the slot's recess (narrow portion of slot).

**Figure 7-2. Fastener Insertion Slot Locations**

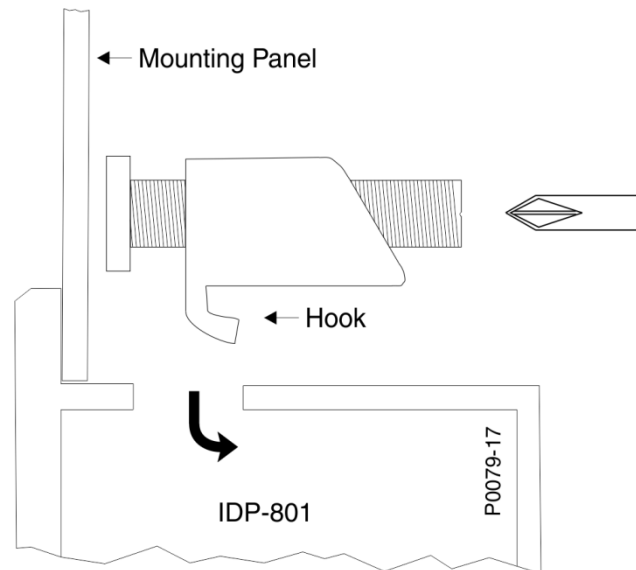

**Figure 7-3. Fastener Attachment Detail**

Secure the IDP-801 in the panel cutout by performing the following steps. Ensure that the IDP-801 mounting gasket is in place before securing the display to the panel.

### Caution

Over-tightening the fastener screws will damage the display panel housing. Maximum screw torque is 4.43 in-lb (0.5 N•m).

1. Insert the IDP-801 into the panel cutout and hold the IDP-801 against the mounting panel.
2. Insert the hook of a hook-and-screw fastener in one of the four fastener insertion slots and rotate the screw clockwise to tighten the screw against the mounting panel.
3. Repeat step 2 for the three remaining fasteners and insertion slots.
4. As necessary, adjust the IDP-801 position in the panel opening so that when the IDP-801 is secured against the panel, it is centered in the panel opening.

## Mounting of Accessories

Mounting details for the optional Ethernet switch and power supply are provided in the following paragraphs.

### Ethernet Switch

The optional, eight-port Ethernet switch (P/N 41133) can be mounted using the DIN mounting rail accessory (P/N 9572818004). DIN mounting rail dimensions are shown in Figure 7-4. Dimensions are shown in inches with millimeters in parenthesis.

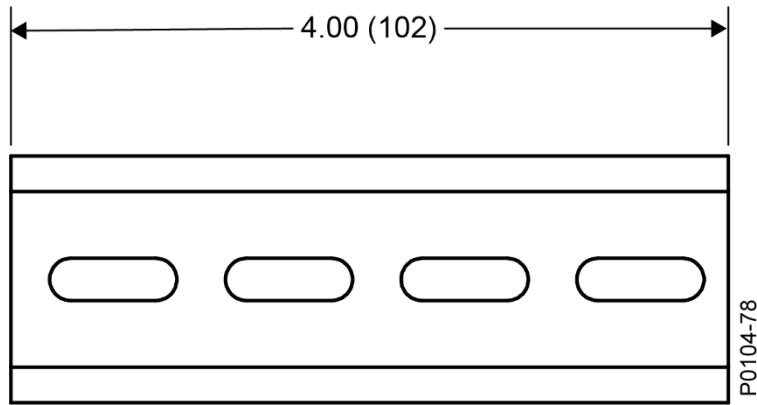

**Figure 7-4. Ethernet Switch and Power Supply Mounting Rail Dimensions**

### **Power Supply**

If an existing, adequate 24 Vdc power source is not available, a separate power supply must be installed to provide the 24 Vdc, 28 W required by the IDP-801. A suitable power supply is available from Basler Electric, which can be mounted using the DIN mounting rail accessory (P/N 9572818004). DIN mounting rail dimensions are shown in Figure 7-4. Request part number 43970.

## 8 • Connections

IDP-801 connections consist of connectors for control power, communication, and flash memory. Connectors are located on the right (Figure 8-1) and bottom (Figure 8-2) sides of the display.

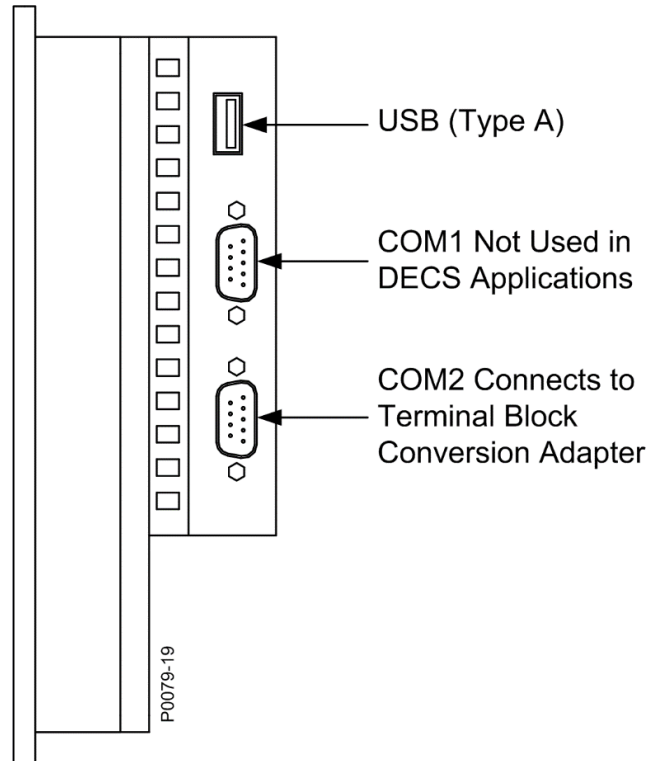

Figure 8-1. IDP-801 Right-Side Connectors

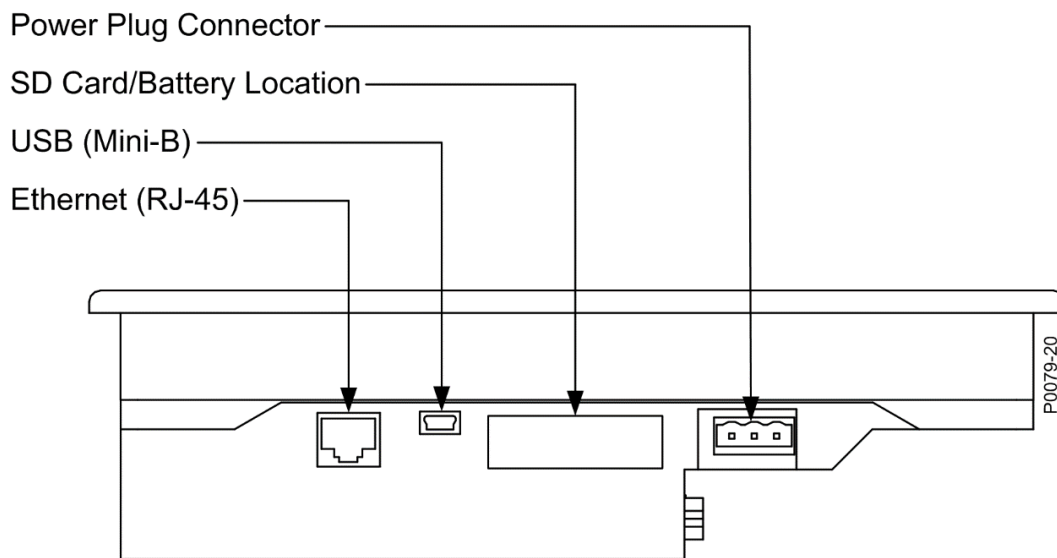
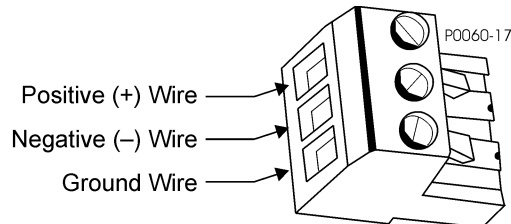

Figure 8-2. IDP-801 Bottom-Side Connectors

## Control Power Connections

IDP-801 control power is provided by a suitably-sized, external 24 Vdc power supply. A power supply is available from Basler Electric; request part number 43970.

The IDP-801 ground and control power wiring connects to the display panel through a three-conductor connector that plugs into a jack located on the bottom side of the IDP-801. Figure 8-1 shows the location of the IDP-801 control power jack. Figure 8-3 illustrates the wire assignments for the connector.



**Figure 8-3. Control Power Connector Wire Assignments**

When connecting the ground and control power wires to the connector, observe the following guidelines:

- Use 18 to 12 AWG (0.75 to 2.5 mm<sup>2</sup>) solid-conductor or stranded-conductor wire.
- Strip each wire end so that 0.28 inches (7 millimeters) of conductor is exposed.
- Secure each wire to the connector using a small, flat-blade screwdriver. The recommended connector screw torque is 5 to 7 in-lb (0.5 to 0.6 N•m).

## Power Supply Connections

Connections for power supply part number 43970 are shown in Figure 8-4. When making power supply connections, observe the following guidelines:

- Protect the power supply input power circuit with a 3.15-ampere, slow-blow fuse
- Use a maximum wire size of 14 AWG (2.5 mm<sup>2</sup>)
- The recommended torque range for the M3.5 terminal screws is 9 to 14 inch-pounds (1.0 to 1.6 N•m)

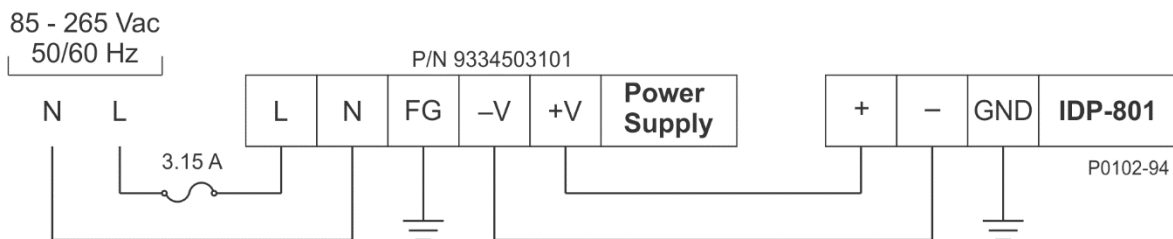

**Figure 8-4. Power Supply Connections**

## Communication Connections

Data and commands can be exchanged between the IDP-801 and DECS-250, DECS-250N, DECS-250E, DECS-400, or DECS-450 using serial communication. In addition to serial communication, the DECS-400 and DECS-450 have the added capability of Ethernet communication with the IDP-801. When connected to an Ethernet LAN, the display can be polled via Modbus to acquire data collected by the DECS connected to the IDP-801.

### Serial Communication

Serial communication between a DECS and IDP-801 requires the use of a terminal conversion adaptor (Figure 8-4) that plugs directly into the IDP-801. The adaptor, provided with the IDP-801, consists of a nine-pin, D-sub plug that mates with IDP-801 connector COM2 (shown in Figure 8-4). A terminal block on the adaptor provides connections for wiring to the RS-485 (Com 2) terminals of the DECS and jumpers required for IDP-801 communication. Terminal block conversion adaptor connections are illustrated in Figure 8-5. Connections between the DECS and adaptor should be made with twisted, shielded conductors.

See the *Communication* chapter for communication setting and application information.

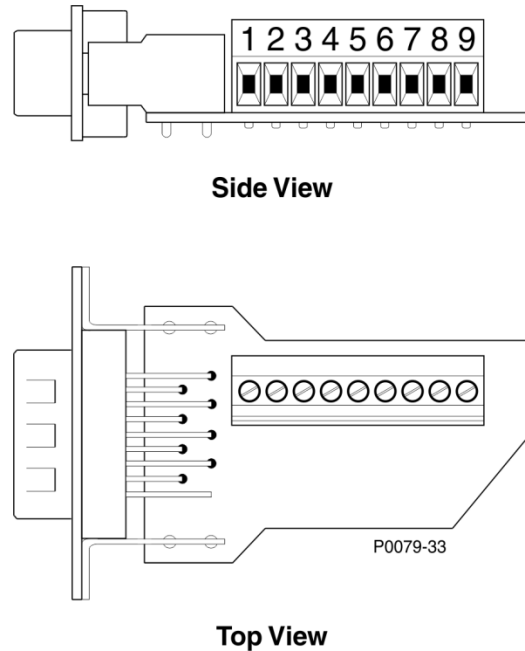
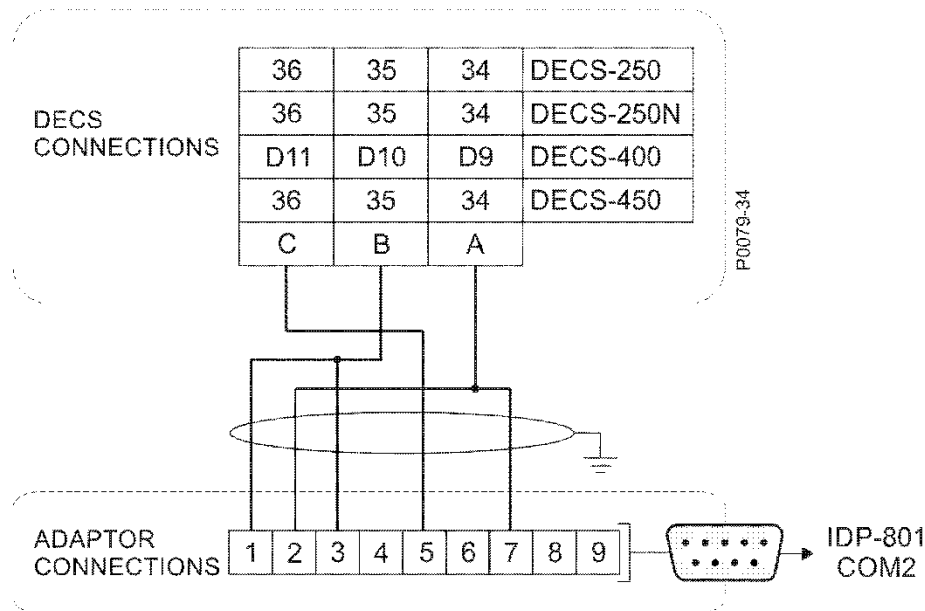

Figure 8-5. Terminal Conversion Adaptor



#### NOTES

1. Twisted, shielded conductors should be used to connect the DECS and IDP-801.
2. Adapter terminal block accepts conductor sizes ranging from 26 to 20 AWG (0.14 mm<sup>2</sup> to 0.5 mm<sup>2</sup>).
3. Jumpers must be installed across terminals 1-3 and 2-7.

Figure 8-6. Terminal Block Conversion Adaptor Connections

**Ethernet Communication**

An Ethernet port enables the IDP-801 to be polled over a LAN/Distributed Control System and provide values of system parameters monitored by the DECS-400 or DECS-450. The IDP-801's 10 Base-T Ethernet interface connects to a LAN through a standard RJ-45 modular jack. This jack is located on the bottom of the display and is shown in Figure 8-2.

# 9 • Maintenance and Troubleshooting

## Maintenance

The IDP-801 requires no maintenance other than periodic cleaning of the touch screen. A Cleaning Lock screen, accessed from the Main View screen, prevents any system control buttons from being pressed during cleaning. When cleaning the touch screen, use nothing more than a soft cloth, water, and mild detergent. Soak the cloth in the solution and wring the cloth tightly before wiping the screen.

## Troubleshooting

A three-color status LED, located on the right side of the IDP-801 frame, indicates display panel status and can be used to determine IDP-801 operating modes. Table 9-1 lists the various status LED states and the conditions that they represent.

**Table 9-1. Status LED Indications**

LED State	Indication
Green, On	In operation, internal logic running
Green, Flashing	In operation, internal logic stopped
Orange, Flashing	Internal logic startup
Red, On	Hardware initialization upon application of control power
Red, Flashing	In operation, internal logic execution error
LED fade (Green)	The unit's "Backlight Control" is set to Standby Mode and the screen has gone blank

### Indications During Normal Startup

Upon application of control power, the status LED is red for one to two seconds. Then, the LED flashes orange and the touch screen is blue while the internal logic starts. Finally, the IDP-801 Configuration screen appears and the status LED changes to green.



# 10 • Specifications

IDP-801 specifications are listed in the following paragraphs.

## **Control Power**

---

Nominal Voltage .....	24 Vdc
Voltage Range.....	19.2 to 28.8 Vdc
Power Dissipation.....	12 W maximum
Inrush Current .....	30 Adc maximum

## **Display**

---

Type.....	TFT color LCD
Size.....	7.5 in (190.5 mm), measured diagonally
Resolution .....	640 (wide) by 480 (high) pixels
Color .....	65 k

## **Communication Interface**

---

Serial.....	RS-485 through 9-pin D-sub connector (COM2)
USB .....	USB 2.0, one Type A port, one Mini Type B port
Ethernet .....	10Base-T/100BASE-TX through RJ-45 connector

## **Environment**

---

Operating Temperature .....	32 to 122°F (0 to 50°C)
Storage Temperature.....	-4 to 140°F (-20 to 60°C)
Humidity.....	10 to 90%, non-condensing

## **Vibration and Shock Resistance**

---

Complies with IEC 61131-2

### **Vibration**

Withstands .....	5 to 9 Hz single amplitude, 3.5 mm
	9 to 150 Hz constant-accelerated velocity, 9.8 m/s <sup>2</sup>
	x, y, and z axes for 10 cycles (100 minutes)

### **Shock**

Withstands .....	147 m/s <sup>2</sup> on x, y, and z axes, 3 times
------------------	---

## **Electrostatic Discharge Immunity**

---

6 kV – complies with EN 61000-4-2 Level 3

## ***Physical***

---

Weight:	2.6 lb (1.2 kg) maximum
Overall Dimensions	
Width:	8.46 in (215 mm)
Height:	6.69 in (170 mm)
Depth:	2.36 in (60 mm)

## ***Certifications***

---

CE, UL Listed CI 1 Div 2, RoHS, ABS (American Bureau of Shipping), DNV (Norway - Marine)





Highland, Illinois USA  
Tel: +1 618.654.2341  
Fax: +1 618.654.2351  
email: [info@basler.com](mailto:info@basler.com)

Suzhou, P.R. China  
Tel: +86 512.8227.2888  
Fax: +86 512.8227.2887  
email: [chinainfo@basler.com](mailto:chinainfo@basler.com)