	www.basler.com +1 618.654.2341 info@basler.com	Model	APR 63-5
		Part Number	9168700107

Introduction

By supplying and controlling the dc exciter field power, the APR 63-5 regulates the output voltage of a conventional, 50 or 60 hertz, brushless generator that has a 63 Vdc field. APR 63-5 voltage regulators are CSA/UL recognized and housed in a rugged, epoxy-potted, plastic case.

The APR 63-5 senses the generator output voltage, converts it to a dc signal, and compares this signal to a reference voltage. An error signal is developed and used to control the dc field power in order to maintain a constant generator output.

Specifications

Power Input

Range: 190 to 277 Vac, $\pm 10\%$,
1-phase
Frequency: 50/60 Hz
Burden: 650 VA

Sensing Input

Configuration: 1-phase, tap-selectable
Frequency: 50/60 Hz
Range
240 V Tap: 190 to 240 Vac, $\pm 10\%$
480 V Tap: 380 to 480 Vac, $\pm 10\%$
Burden: 5 VA maximum

Power Output

Ratings

Maximum Continuous: 5.0 Adc, 63 Vdc, 315 W
One Minute Forcing: 8.5 Adc, 105 Vdc, 893 W

DC Field Resistance

Minimum: 12.6 Ω
Maximum: 100 Ω

Voltage Adjustment

Internal Control

Range
240 V Tap: 170 to 264 Vac
480 V Tap: 340 to 528 Vac

External Control

Provided by an optional, 1,000 Ω , 2 W potentiometer (Basler P/N 17727).

Voltage Buildup

Buildup is automatic from generator residual voltage as low as 6 Vac.

Frequency Compensation

See Figure 1.

Publication	Revision	<h1>Instructions</h1>	Date	Page
9168700991	K		July 2026	1 of 10

Overexcitation Shutdown

Output power is removed instantaneously if the field voltage exceeds 135 Vdc, ± 5 Vdc. Output power is removed after a time delay that is inversely proportional to the voltage magnitude when the field voltage exceeds 100 Vdc, ± 5 Vdc.

Agency Certifications

UL 6200:2019 recognized and CSA certified.

China RoHS

The following table serves as the declaration of hazardous substances for China in accordance with PRC standard SJ/T 11364-2014. The EFUP (Environment Friendly Use Period) for this product is 40 years.

PRODUCT:	APR63-5									
零件名称 Part Name	有害物质 Hazardous Substances									
	铅 Lead (Pb)	汞 Mercury (Hg)	镉 Cadmium (Cd)	六价铬 Hexavalent Chromium (Cr ⁶⁺)	多溴联苯 Polybrominated Biphenyls (PBB)	多溴二苯醚 Polybrominated Diphenyl Ethers (PBDE)	邻苯二甲酸二丁酯 Dibutyl Phthalate (DBP)	邻苯二甲酸丁苄酯 Benzyl butyl phthalate (BBP)	邻苯二甲酸二酯 Bis(2- ethylhexyl) phthalate (BEHP)	邻苯二甲酸二异丁酯 Diisobutyl phthalate (DIBP)
金属零件 Metal parts	O	O	O	O	O	O	O	O	O	O
聚合物 Polymers	O	O	O	O	O	O	O	O	O	O
电子产品 Electronics	X	O	O	O	O	O	O	O	O	O
电缆和互连配件 Cables & interconnect accessories	O	O	O	O	O	O	O	O	O	O
绝缘材料 Insulation material	O	O	O	O	O	O	O	O	O	O

本表格依据 SJ/T11364 的规定编制。

O: 表示该有害物质在该部件所有均质材料中的含量均在 GB/T 26572 规定的限量要求以下。

X: 表示该有害物质至少在该部件的某一均质材料中的含量超出 GB/T 26572 规定的限量要求。

This form was prepared according to the provisions of standard SJ/T11364.

O: Indicates that the hazardous substance content in all homogenous materials of this part is below the limit specified in standard GB/T 26252.

X: Indicates that the hazardous substance content in at least one of the homogenous materials of this part exceeds the limit specified in standard GB/T 26572.

Temperature

Operating: -40 to 60°C (-40 to 140°F)

Storage: -65 to 85°C (-85 to 185°F)

Overexcitation Shutdown Protection

If the exciter field voltage exceeds 100 Vdc (± 5 Vdc), the APR 63-5 automatically removes field power after a time delay. This delay is inversely proportional to the magnitude of the overvoltage. Figure 2 illustrates the inverse time characteristic. At 135 Vdc (± 5 Vdc), field power is removed instantaneously.

When field power is removed due to overexcitation, the APR 63-5 will not reset or return to operation until the generator output decreases to less than 6 Vac for a minimum of 10 seconds.

Publication 9168700991	Revision K	Instructions	Date July 2026	Page 2 of 10
----------------------------------	----------------------	---------------------	--------------------------	------------------------

Regulator Controls

APR 63-5 controls are illustrated in Figure 3 and consist of FREQ, STAB, and VOLT.

FREQ

This control prevents generator and regulator damage when the generator frequency decreases by decreasing the generator output voltage. To adjust the FREQ control:

1. Set the generator rpm at the desired frequency roll-off.
2. Adjust the FREQ control until the voltage begins to decrease.
3. Increase the generator speed to nominal. The output voltage should be at nominal.

STAB

This control enables adjustment of the generator response time (and thus voltage stability). Use an oscilloscope or other voltage recording device to set this control. Observe the following guidelines when adjusting the STAB control.

- Counterclockwise rotation of the STAB control reduces the voltage response time. If rotated too far, the generator voltage will hunt (oscillate).
- Rotate the STAB control clockwise, just past the point where voltage oscillation occurs.

VOLT

Observe the following guidelines when adjusting the VOLT control.

- Clockwise rotation of the VOLT control increases the generator output voltage.
- Replacing the jumper across terminals 6 and 7 with an external potentiometer (1,000 Ω , 2 W) gives a $\pm 10\%$ voltage adjustment range with the nominal value set by the VOLT control.

Accessory Equipment

The following equipment is available as options to the APR 63-5:

- BE18674001 power isolation transformer
- APM 2000 and CT for parallel compensation
- MVC 300 for manual voltage control
- CBS 305 Current Boost System

Mounting

The APR 63-5 can be mounted in any convenient position and may be mounted directly on the generator set. Figure 3 illustrates the mounting dimensions. Use #11 (ANSI) or M5 (metric) mounting hardware.

Interconnection

Connect the APR 63-5 by performing the following steps. Figure 4, Figure 5, and Figure 6 illustrate typical APR63-5 connections. The torque applied to the terminal block screws should not exceed 9 inch pounds (1 Newton meter).

1. Configure the regulator's nominal frequency by connecting the jumper from COM to either the 50 Hz or 60 Hz terminal.
2. If using a CBS 305 with the APR 63/5, remove the jumper from APR 63-5 terminals CB- and CB+ and connect those terminals to the CBS 305.
3. Connect APR 63-5 terminals F+ and F- to the exciter field. Observe proper polarity.
4. For regulator power, connect terminals 3 and 4 to the generator stator. Fuse both leads with 5 A, 250 V, high interrupting capacity, fast-blowing fuses. If desired, install a shutdown switch.
5. Connect the line-to-line generator sensing to the regulator. Generator sensing connects to terminals 4 and either 240 or 480, depending upon the generator voltage.

Publication 9168700991	Revision K	Instructions	Date July 2026	Page 3 of 10
----------------------------------	----------------------	---------------------	--------------------------	------------------------

Operation

The following procedures are provided for APR 63-5 setup and commissioning.

Caution

Meggers and high-potential test equipment must not be used. Incorrect use of such equipment could damage the semiconductors contained in the regulator.

Preliminary Setup

To prevent damage to the regulator, perform the following steps before proceeding with system startup.

1. Verify that the APR 63-5's specifications are compatible with the generator system requirements.
2. Ensure that the regulator is connected correctly. See Figures, 4, 5, and 6.
3. Install fuses per step 4 of *Interconnection*.

During periods of prime mover idling, use the excitation shutdown switch.

System Startup

1. Start the prime mover and bring it up to rated speed. The generator voltage should build up. If a minimum residual generator voltage of 6 Vac is not present, perform the procedure under *Field Flashing*.
2. Slowly adjust the regulator VOLT control until the voltage reaches the nominal value. If used, adjust the remote voltage adjust potentiometer to set the generator output to the desired value.
3. Apply and remove load to check for stability. If the voltage is unstable, refer to the guidelines under *Regulator Controls, STAB*.
4. Reduce the generator frequency (speed) to 55 Hz (on 60 Hz systems) or 45 Hz (on 50 Hz systems). Verify that the generator output decreases from this point. If it does not, refer to the steps under *Regulator Controls, FREQ*.

Field Flashing

When the generator is operated with the regulator for the first time, the polarity of the generator's residual magnetism may not be correct or the magnitude may not be enough for reliable voltage buildup. If the generator voltage does not build up, stop the prime mover and proceed as follows:

1. With the prime mover at rest, apply an ungrounded dc source of not more than 48 Vdc to terminals F+ and F- in series with a limiting resistor. Use 1 Ω of resistance for each volt from the dc source. The resistor should have a power rating of at least 1 watt per volt.
2. Allow approximately 30 seconds to elapse before removing the dc source.
3. Start the prime mover and measure the voltage at regulator terminals 3 and 4. If the voltage is greater than 6 Vac, voltage buildup should occur. Repeat the flashing procedure if less than 6 Vac is measured.

Operational Test

If desired, perform the following steps to perform a bench test of APR 63-5 operation.

1. Connect the APR 63-5 and apply 240 Vac as shown in Figure 7.
2. Rotate the VOLT control fully counter-clockwise. The lamp should not be lit.
3. Rotate the VOLT control fully clockwise. The lamp should be lit.
4. Rotate the VOLT control counterclockwise until the lamp turns off.

Publication 9168700991	Revision K	Instructions	Date July 2026	Page 4 of 10
----------------------------------	----------------------	---------------------	--------------------------	------------------------

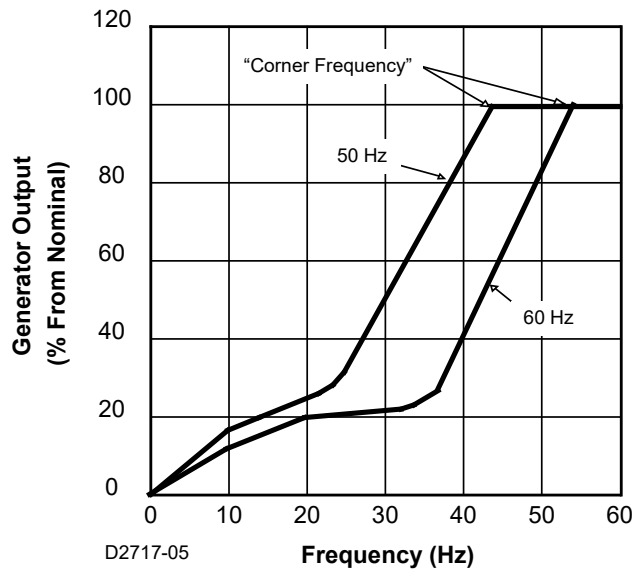

Figure 1. Frequency Compensation Curves

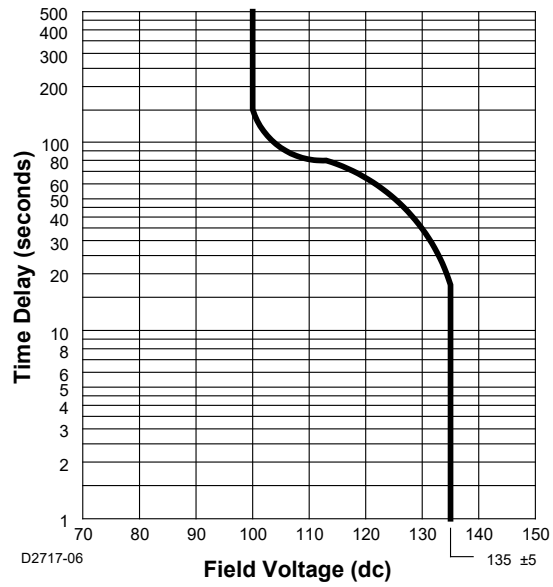
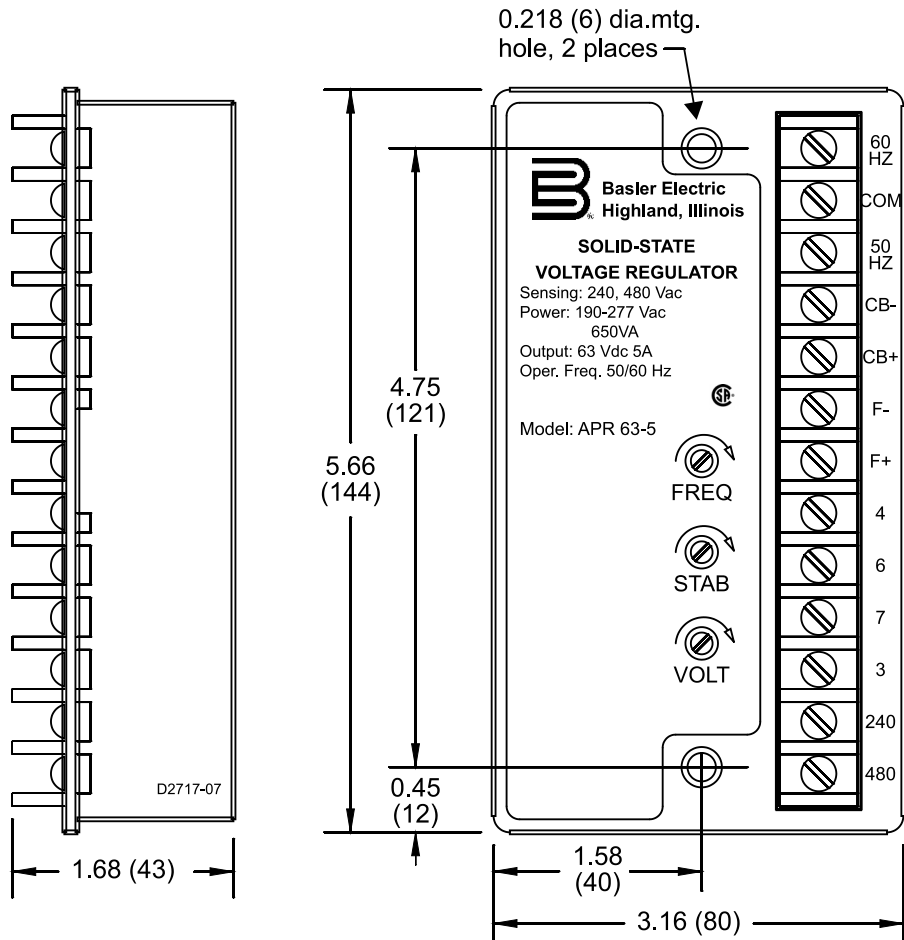

Figure 2. Typical Inverse Time Characteristic Curve

Publication 9168700991	Revision K	<i>Instructions</i>	Date July 2026	Page 5 of 10
----------------------------------	----------------------	----------------------------	--------------------------	------------------------



NOTE: All dimensions are in inches (millimeters).

Figure 3. APR 63-5 Mounting Dimensions and Controls Illustration

Publication	Revision	Instructions		Date	Page
9168700991	K			July 2026	6 of 10

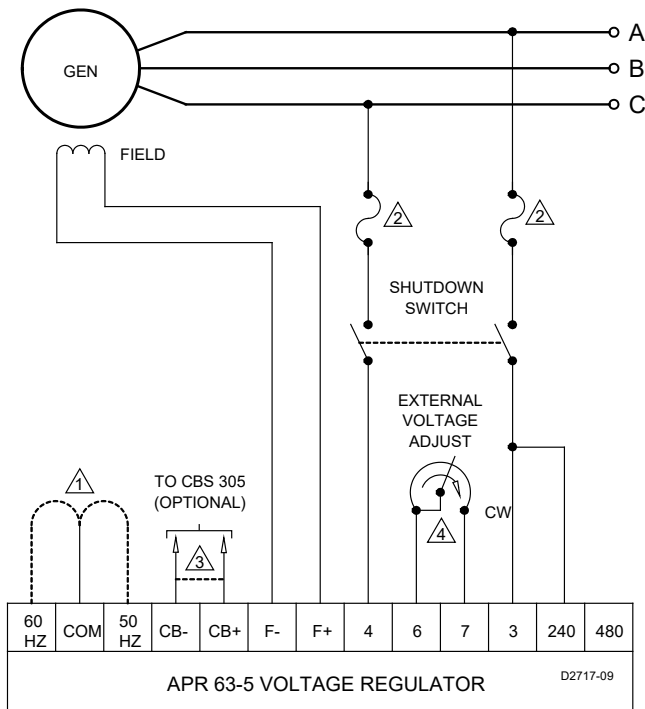

- ⚠️ 1 Jumper for 60 Hz or 50 Hz.
- ⚠️ 2 Use 5 A, 250 V, fast-blowing, high-interrupting capacity fuses.
- ⚠️ 3 Remove jumper if CBS 305 is used.
- ⚠️ 4 If external voltage adjust is not used, jumper terminals 6 and 7.

Figure 4. Typical Single-Phase Connections

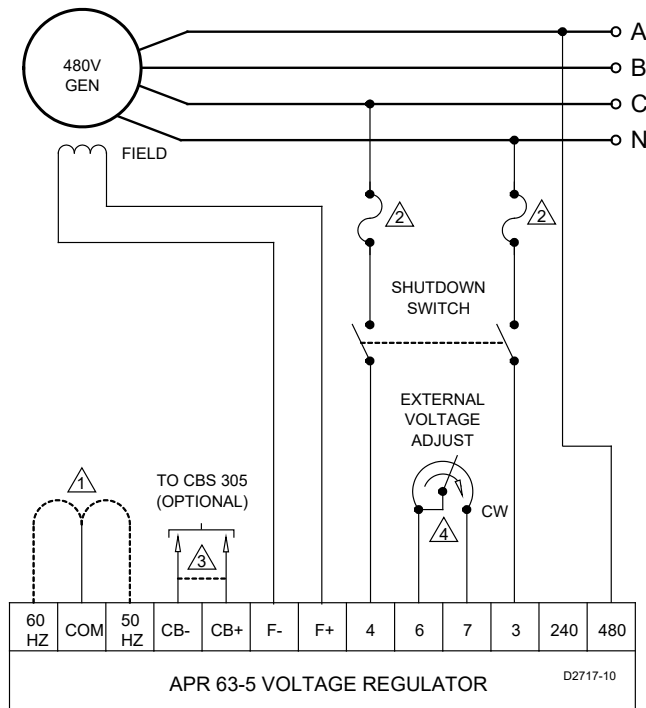

- ⚠️ 1 Jumper for 60 Hz or 50 Hz.
- ⚠️ 2 Use 5 A, 250 V, fast-blowing, high-interrupting capacity fuses.
- ⚠️ 3 Remove jumper if CBS 305 is used.
- ⚠️ 4 If external voltage adjust is not used, jumper terminals 6 and 7.

Figure 5. Typical Connections for 480 Vac

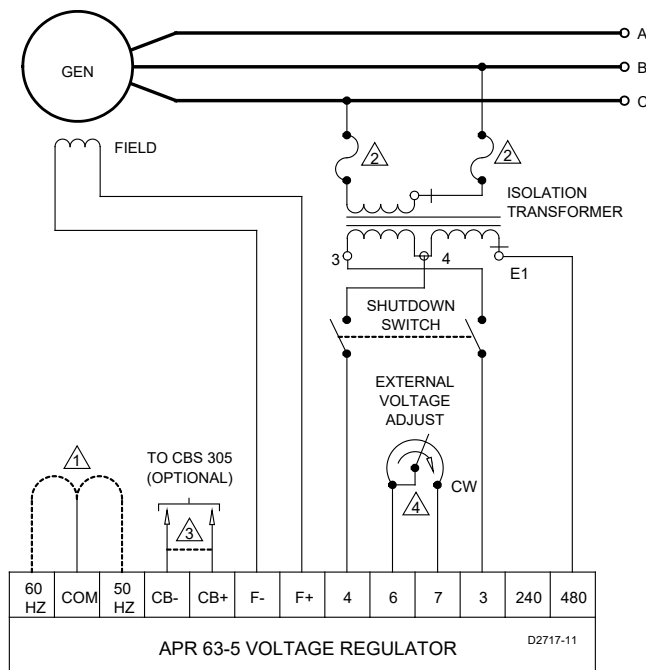

- ⚠️ 1 Jumper for 60 Hz or 50 Hz.
- ⚠️ 2 Use 5 A, 250 V, fast-blowing, high-interrupting capacity fuses.
- ⚠️ 3 Remove jumper if CBS 305 is used.
- ⚠️ 4 If external voltage adjust is not used, jumper terminals 6 and 7.

Figure 6. Typical Connections with Isolation Transformer

Publication 9168700991	Revision K	Instructions	Date July 2026	Page 8 of 10
----------------------------------	----------------------	---------------------	--------------------------	------------------------

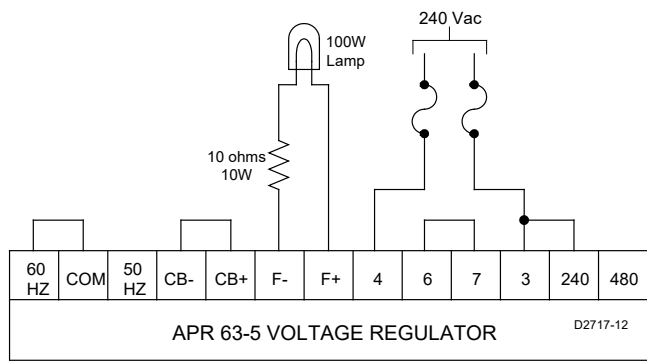

Figure 7. Operational Test Connections

Publication 9168700991	Revision K	<h1 style="margin: 0;">Instructions</h1>	Date July 2026	Page 9 of 10
----------------------------------	----------------------	------------------------------------------	--------------------------	------------------------



Publication 9168700991	Revision K	<i>Instructions</i>	Date July 2026	Page 10 of 10
----------------------------------	----------------------	----------------------------	--------------------------	-------------------------

For terms of service relating to this product and software, see the *Commercial Terms of Products and Services* document available at www.basler.com/terms.