	www.basler.com +1 618.654.2341 (USA) info@basler.com	Model	BE350
		Part Number	9166800143

Introduction

The BE350 analog voltage controller regulates voltage on a 50 or 60 hertz brushless generator. Controller features include frequency compensation, solid-state buildup circuitry, and EMI filtering.

Specifications

Output Power

Maximum Continuous: 3.5 A_{dc} at 73 V_{dc} (255 W)
One-Minute Forcing: 5 A_{dc} at 105 V_{dc} (525 W) with 240 V_{ac} power input

Exciter Field DC Resistance

Minimum: 21 Ω

Input Power

Range: 190–240 V_{ac}, ±10%, 1-phase
Frequency: 50/60 Hz, ±10%
Burden: 500 VA

Sensing Input

Common with ac power input: 190–240 V_{ac}, single-phase, 50/60 Hz, ±10%

Fuse

Bussmann GDC-4A or equivalent
Rating: 4 A_{ac}, 250 V_{ac}
Type: Glass tube, 5 x 20 mm, time delayed

Voltage Adjustment Range

171 to 264 V_{ac}

Regulation Accuracy

Better than ±1.0%, no-load to full-load

Response Time

Less than 1.5 cycles for ±5% change in sensing voltage

EMI Suppression

Internal electromagnetic interference (EMI) filtering

Voltage Buildup

Automatic voltage buildup occurs for residual generator voltages as low as 10 V_{ac}.

Power Dissipation

8 W maximum

Temperature

Operating: –40 to 60°C (–40 to 140°F)
Storage: –65 to 85°C (–85 to 185°F)

Vibration

2 to 27 Hz: 1.3 G
27 to 52 Hz: 0.914 mm, double-amplitude
52 to 1000 Hz: 5 G

Shock

Withstands up to 20 G in each of three mutually perpendicular axes.

Publication	Revision	<h1>Instructions</h1>	Date	Copyright
9166800893	D		July 2026	2026

Weight

184 g (6.5 oz) net

Agency Certification

UL 6200:2019 recognized and CSA certified.

China RoHS

The following table serves as the declaration of hazardous substances for China in accordance with PRC standard SJ/T 11364-2014. The EFUP (Environment Friendly Use Period) for this product is 40 years.

PRODUCT: BE350		有害物质 Hazardous Substances								
零件名称 Part Name	铅 Lead (Pb)	汞 Mercury (Hg)	镉 Cadmium (Cd)	六价铬 Hexavalent Chromium (Cr ⁶⁺)	多溴联苯 Polybrominated Biphenyls (PBB)	多溴二苯醚 Polybrominated Diphenyl Ethers (PBDE)	邻苯二甲酸二丁酯 Dibutyl Phthalate (DBP)	邻苯二甲酸丁苄酯 Benzyl butyl phthalate (BBP)	邻苯二甲酸二酯 Bis(2-ethylhexyl) phthalate (BEHP)	邻苯二甲酸二异丁酯 Diisobutyl phthalate (DIBP)
金属零件 Metal parts	X	O	O	O	O	O	O	O	O	O
聚合物 Polymers	O	O	O	O	O	O	O	O	O	O
电子产品 Electronics	X	O	O	O	O	O	O	O	O	O
电缆和互连配件 Cables & interconnect accessories	O	O	O	O	O	O	O	O	O	O
绝缘材料 Insulation material	O	O	O	O	O	O	O	O	O	O

本表格依据 SJ/T11364 的规定编制。

O: 表示该有害物质在该部件所有均质材料中的含量均在 GB/T 26572 规定的限量要求以下。

X: 表示该有害物质至少在该部件的某一均质材料中的含量超出 GB/T 26572 规定的限量要求。

This form was prepared according to the provisions of standard SJ/T11364.

O: Indicates that the hazardous substance content in all homogenous materials of this part is below the limit specified in standard GB/T 26252.

X: Indicates that the hazardous substance content in at least one of the homogenous materials of this part exceeds the limit specified in standard GB/T 26572.

Controls

BE350 controls consist of jumpers and screwdriver-adjusted potentiometers.

Potentiometer Controls

BE350 potentiometer controls are accessible through the controller front panel and are shown in Figure 1.

VOLT Control

This control raises and lowers the generator output voltage.

STAB Control

This control adjusts the stability by increasing and reducing the response time of the BE350.

U/F Control

This control adjusts the corner frequency point of the BE350 frequency compensation characteristic.

Jumpers

Two jumpers control BE350 operation: the Corner Frequency jumper and the Voltage Adjust Rheostat jumper. These jumpers are shown in Figure 2.

Corner Frequency Jumper

Publication 9166800893	Revision D	Instructions	Date July 2026	Page 2 of 6
----------------------------------	----------------------	---------------------	--------------------------	-----------------------

BE350 controllers are delivered with the Corner Frequency jumper set for 50 hertz operation. This gives a corner frequency of 45 hertz. For 60 hertz operation and a corner frequency of 55 hertz, the Corner Frequency jumper must be moved to the 60 Hz terminal.

Voltage Adjust Rheostat Jumper

BE350 controllers are delivered with the Voltage Adjust Rheostat jumper connected across terminals 6 and 7. This enables adjustment of the generator output voltage through the controller's internal Voltage Control potentiometer. Clockwise rotation of the Voltage Control potentiometer increases the generator voltage.

If remote adjustment of the generator output is desired, the Voltage Adjust Rheostat jumper must be replaced with a user-supplied rheostat. A 2000 ohm, ½ watt rheostat will provide adequate voltage adjustment for most applications. Figure 5 shows the proper remote rheostat connections.

Input Power/Sensing Input

Power for the exciter field and BE350 is derived from the generator output. The acceptable power input range is 171 to 264 Vac. Connect the input power wiring to terminals 3 and 4 as shown in Figure 5.

Exciter Field Power Circuit

Controller terminal F+ is connected to the brushless exciter field positive terminal and controller terminal F– is connected to the brushless exciter field negative terminal.

Caution
The exciter field dc resistance must be no less than 21 ohms.

If the exciter field dc resistance is less than 21 ohms and the full-load field current does not exceed the maximum continuous current rating of the controller, a resistor of sufficient wattage must be added in series with the field to increase the total resistance to 21 ohms.

Frequency Compensation

The frequency compensation feature improves system load pickup performance by restraining voltage recovery until the frequency has also started to recover. Figure 3 illustrates the underfrequency characteristics of the BE350.

The corner frequency range is set for 50 hertz or 60 hertz by connecting the Corner Frequency jumper to the appropriate terminal. Refer to *Controls, Jumpers* for details about selecting the corner frequency range.

The corner frequency setting is adjusted by the Underfrequency control (potentiometer). Clockwise rotation of the Underfrequency control increases the corner frequency and counterclockwise rotation decreases the corner frequency. If user adjustment of the factory-set potentiometer is desired, follow the *Preliminary Setup* and *System Startup* procedures.

Installation

Mounting

The BE350 controller may be mounted on the generator in any convenient position. Figure 4 shows the mounting dimensions. Dimensions are shown in inches with millimeters in parenthesis.

The recommended mounting hardware is two #8 or M4 screws tightened to a torque of 9 inch-pounds (1 newton meter). Nylon-lined locking nuts are recommended when installing the controller with loose hardware.

Connections

BE350 controller terminals consist of quarter-inch, quick-connect tabs.

Figure 5 shows typical connections for the BE350 controller.

Operating Procedures

The following procedures can be used when adjusting the BE350 controller. Symptoms caused by certain generator system problems or a faulty controller are included along with suggested remedies.

Caution
Meggers and high-potential test equipment must not be used. Use of such equipment could damage the semiconductors contained in the controller.

Preliminary Setup

Complete the following steps before proceeding with system startup.

1. Verify that the BE350 specifications conform with the requirements of the generator system.
2. Ensure that the controller jumpers are positioned as follows.
 - a. If a remote voltage adjust rheostat will not be used, ensure that the Voltage Adjust Rheostat jumper is connected across terminals 6 and 7.
 - b. If a 55 hertz corner frequency for a 60 hertz system is desired, connect the Corner Frequency jumper to the 60 Hz terminal. If a 45 hertz corner frequency for a 50 hertz system is desired, connect the Corner Frequency jumper to the 50 Hz terminal.
3. Ensure that the connections between the generator system and the controller are correct.
4. Set the BE350 Voltage control fully counterclockwise and the remote voltage adjust rheostat (if used) to the center position.
5. Adjust the BE350 Stability control fully clockwise. This provides the most stability and the slowest response.
6. If user adjustment of the Underfrequency control is required, start with the potentiometer adjusted to the fully counterclockwise position. Then, slowly adjust the potentiometer clockwise to set.

System Startup

Note
Use an average-reading voltmeter for all voltage readings.

1. Perform the steps under *Preliminary Setup*.
2. Start the prime mover and bring it up to rated speed. Generator voltage should build up.
3. Slowly adjust the BE350 Voltage control (or remote voltage adjust rheostat) until the generator voltage reaches the nominal level.

If the voltage does not build up to the rated level, check the generator output for excessive load or a short-circuit.

4. Apply and remove the generator load to verify stability.

If the generator responds too slowly or hunts (oscillates), check the generator output for excessive load or a short-circuit. Adjust the controller's Stability control with no load applied.

5. Check regulation under normal operating conditions. If the regulation is poor:
 - a. Verify that the prime mover is operating at rated speed.
 - b. Verify that the voltmeter is connected to the same point as the controller sensing.
 - c. Use an average-sensing voltmeter (not an rms-sensing voltmeter).
6. Verify the corner frequency setting by slowly reducing the generator frequency until the generator output voltage just starts to decrease.

If adjustment of the corner frequency is required:

- a. Rotate the Underfrequency control fully counter-clockwise.
- b. Reduce the generator frequency from nominal (either 50 Hz or 60 Hz) to the desired corner frequency.
- c. Slowly adjust the Underfrequency control clock-wise until the generator output voltage just starts to decrease.

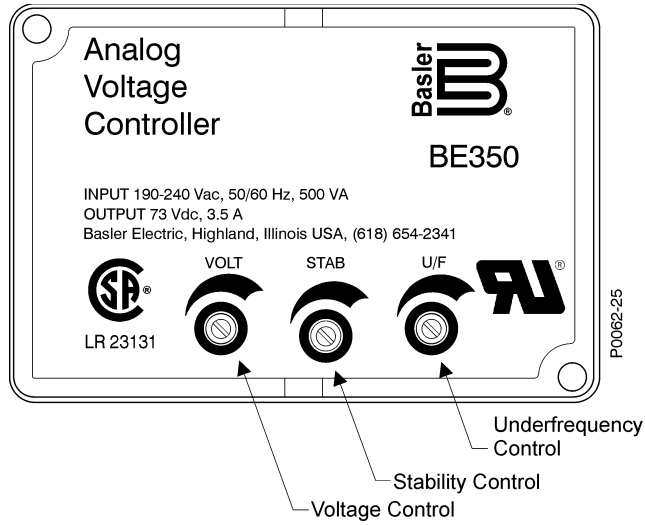

Figure 1. Potentiometer Controls

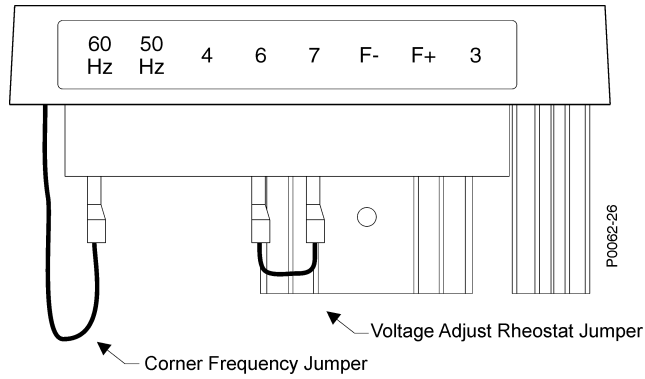

Figure 2. Jumper Locations

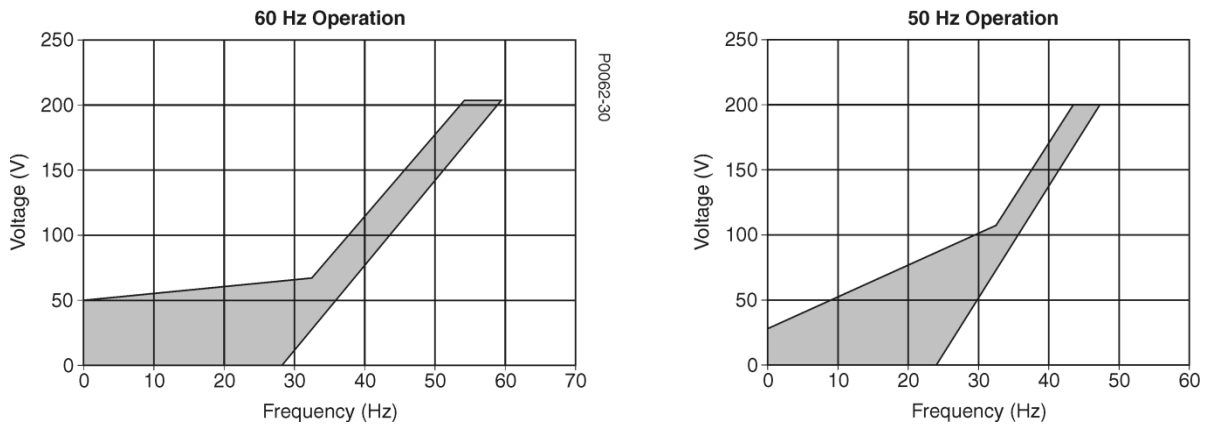

Figure 3. Frequency Compensation Characteristics

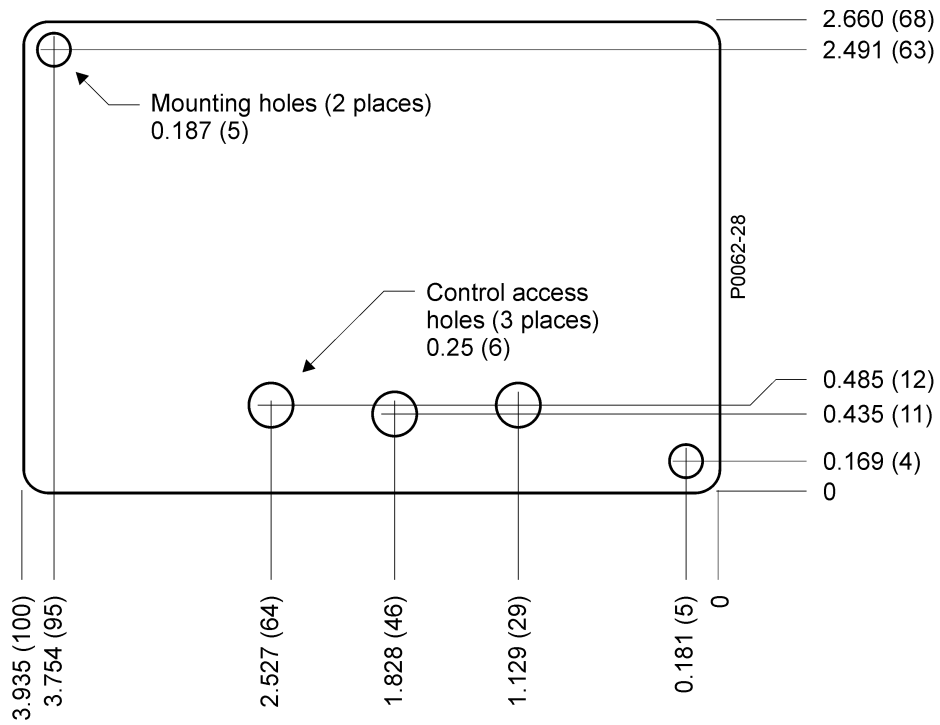

Figure 4. Panel Drilling and Mounting Dimensions

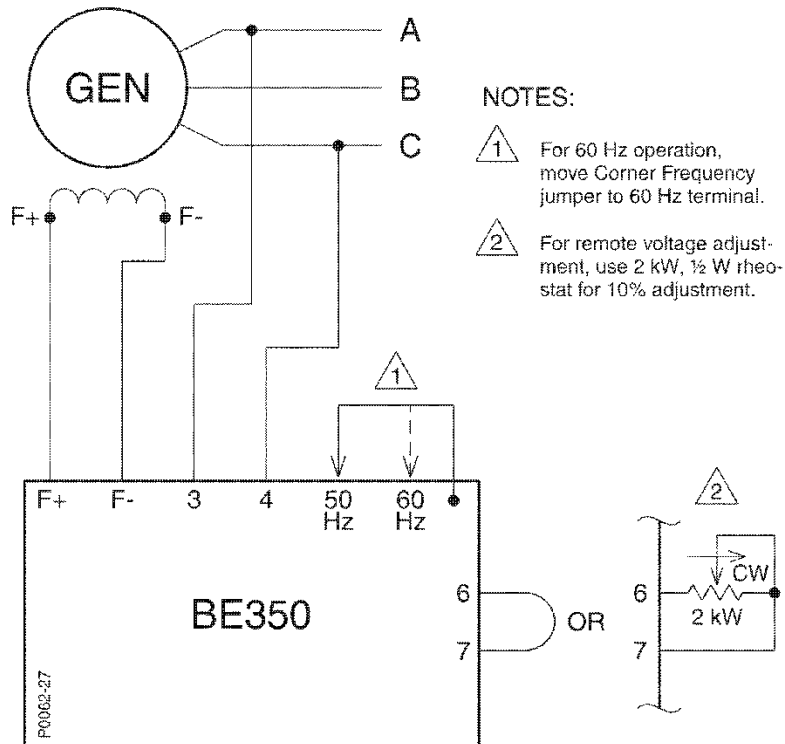

Figure 5. Typical Connections