



www.basler.com
+1 618.654.2341 (USA)
info@basler.com

Model

MVC-300

Purpose

The MVC-300 Manual Voltage Control is used as a backup control device to provide manual voltage control in case of a voltage regulator failure. The MVC-300 can be mounted on a control panel in ground vehicles, stationary equipment, or shipboard locations.

Description

The solid-state MVC-300 is enclosed in a metal chassis and designed for “through-the-hole” mounting. MVC-300 controls are located on the front panel and include a Manual Voltage Adjust potentiometer and an Auto-Off-Manual control switch. MVC-300 connections are made at a terminal strip located on the rear panel. Figure 1 illustrates the front and rear panels of the MVC-300.

Specifications

Input Power:	120 Vac or 240 Vac, single-phase
Output Adjustment Range	120 Vac Input: 1 to 32 Vdc or 1 to 63 Vdc 240 Vac Input: 1 to 63 Vdc or 1 to 125 Vdc
Power Dissipation:	30 W maximum
Minimum Residual Voltage for Buildup:	6 Vac
Temperature	
Operating:	−40 to 158°F (−40 to 70°C)
Storage:	−85 to 212°F (−65 to 100°C)
Weight:	
Net:	3.0 lb. (1.36 kg)
Shipping:	5.0 lb. (2.25 kg)
Shock:	Withstands up to 15 g in each of three mutually perpendicular axes.
Vibration:	Withstands 5 to 27 Hz at 1.3 g, 27 to 52 Hz at 0.036 in. double amplitude, and 52 to 500 Hz at 5 g.
EC Directive:	RoHS 2 2011/65/EU

Agency Certification

UL 6200:2019 recognized.

Publication	Revision	Instructions	Date	Copyright
9121000993	M		July 2026	2026

For terms of service relating to this product and software, see the *Commercial Terms of Products and Services* document available at <https://www.basler.com>.

China RoHS

The following table serves as the declaration of hazardous substances for China in accordance with PRC standard SJ/T 11364-2014. The EFUP (Environment Friendly Use Period) for this product is 40 years.

PRODUCT: MVC-300										
零件名称 Part Name	有害物质 Hazardous Substances									
	铅 Lead (Pb)	汞 Mercury (Hg)	镉 Cadmium (Cd)	六价铬 Hexavalent Chromium (Cr ⁶⁺)	多溴联苯 Polybrominated Biphenyls (PBB)	多溴二苯醚 Polybrominated Diphenyl Ethers (PBDE)	邻苯二甲酸二丁酯 Dibutyl Phthalate (DBP)	邻苯二甲酸丁苄酯 Benzyl butyl phthalate (BBP)	邻苯二甲酸二酯 Bis(2- ethylhexyl) phthalate (BEHP)	邻苯二甲酸二异丁酯 Diisobutyl phthalate (DIBP)
金属零件 Metal parts	O	O	O	O	O	O	O	O	O	O
聚合物 Polymers	O	O	O	O	O	O	O	O	O	O
电子产品 Electronics	X	O	O	O	O	O	O	O	O	O
电缆和互连配件 Cables & interconnect accessories	O	O	O	O	O	O	O	O	O	O
绝缘材料 Insulation material	O	O	O	O	O	O	O	O	O	O

本表格依据 SJ/T11364 的规定编制。

O: 表示该有害物质在该部件所有均质材料中的含量均在 GB/T 26572 规定的限量要求以下。

X: 表示该有害物质至少在该部件的某一均质材料中的含量超出 GB/T 26572 规定的限量要求。

This form was prepared according to the provisions of standard SJ/T11364.

O: Indicates that the hazardous substance content in all homogenous materials of this part is below the limit specified in standard GB/T 26252.

X: Indicates that the hazardous substance content in at least one of the homogenous materials of this part exceeds the limit specified in standard GB/T 26572.

Functional Description

The MVC-300 controls voltage through a phase-controlled SCR rectifier bridge. Adjusting the front-panel Manual Voltage Adjust control alters the SCR firing angle and adjusts the level of voltage supplied to the exciter field.

During startup, the internal buildup circuit holds the SCR power bridge at maximum output. Once the voltage builds to approximately 30 Vac, the buildup circuit relinquishes control to the external Manual Voltage Adjust control.

The front-panel Auto-Off-Manual control mode switch provides the ability to transfer from voltage regulator control to the MVC-300 and vice versa. An internal freewheeling diode connected to the field allows safe switching without the risk of arcing.

The MVC-300 operates from a nominal 120 Vac or 240 Vac source without the need for any electrical wiring changes such as tap selection or terminal connections. Taps are provided to select a 32 Vac, 63 Vac, or 125 Vac maximum output.

Publication 9121000993	Revision M	Instructions	Date July 2026	Page 2 of 10
----------------------------------	----------------------	---------------------	--------------------------	------------------------

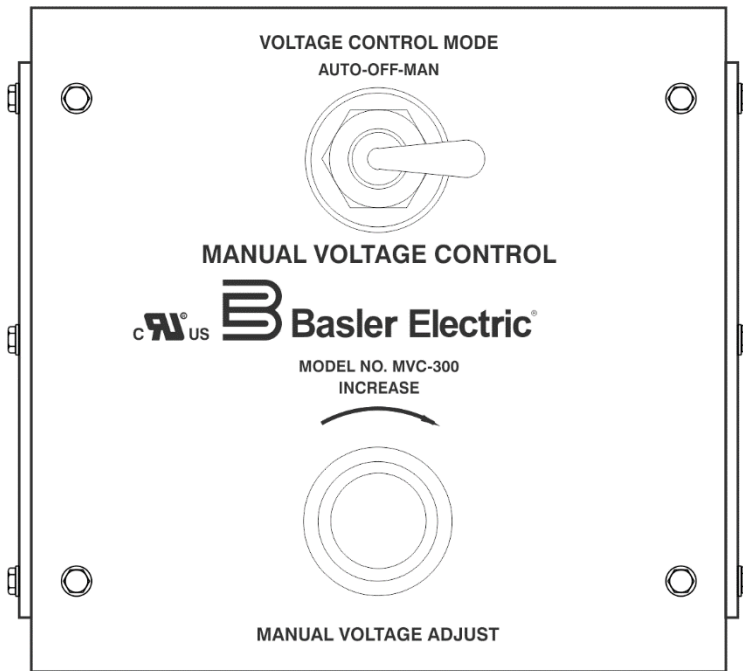

P0103-10

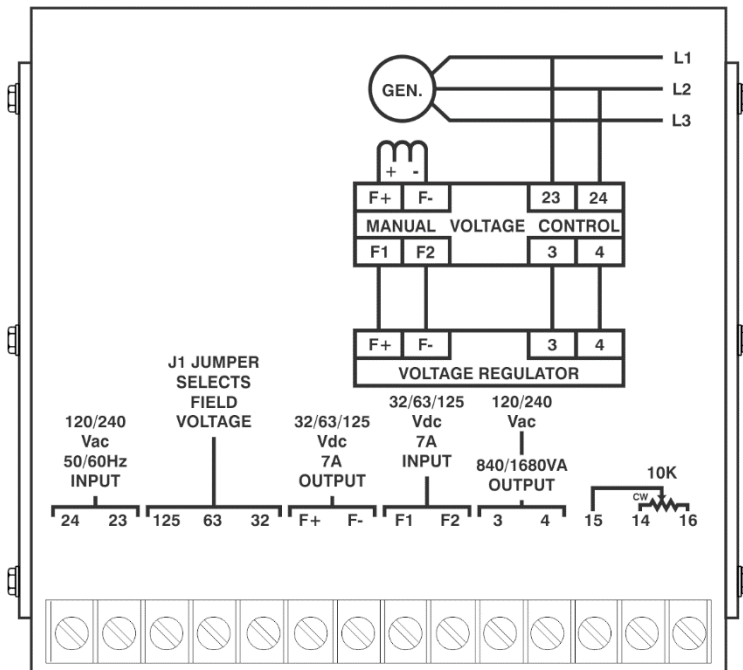

Figure 1. MVC-300 Front and Rear Panels

Mounting

The MVC-300 is designed for “through-the-panel” mounting. It can be installed in any position but vertical mounting is preferred to improve ventilation/cooling.

Overall mounting dimensions are shown in Figure 2. The front panel of the MVC-300 can be removed and relocated. Figure 3 illustrates the panel drilling dimensions for relocating the front panel. All dimensions are expressed in inches with millimeters in parenthesis. Maximum mounting panel thickness is 0.31 inches (8 mm).

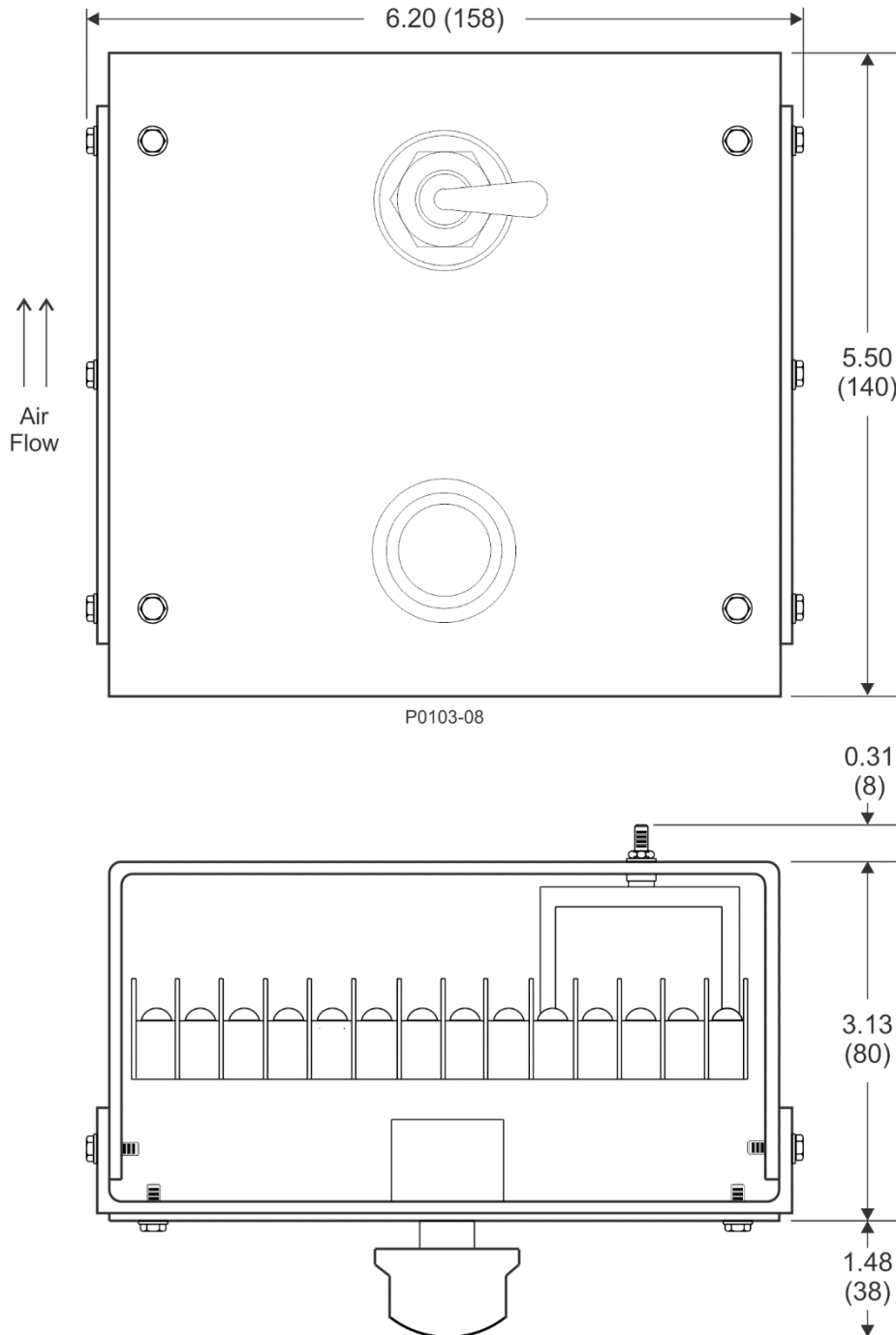

Figure 2. MVC-300 Mounting Dimensions

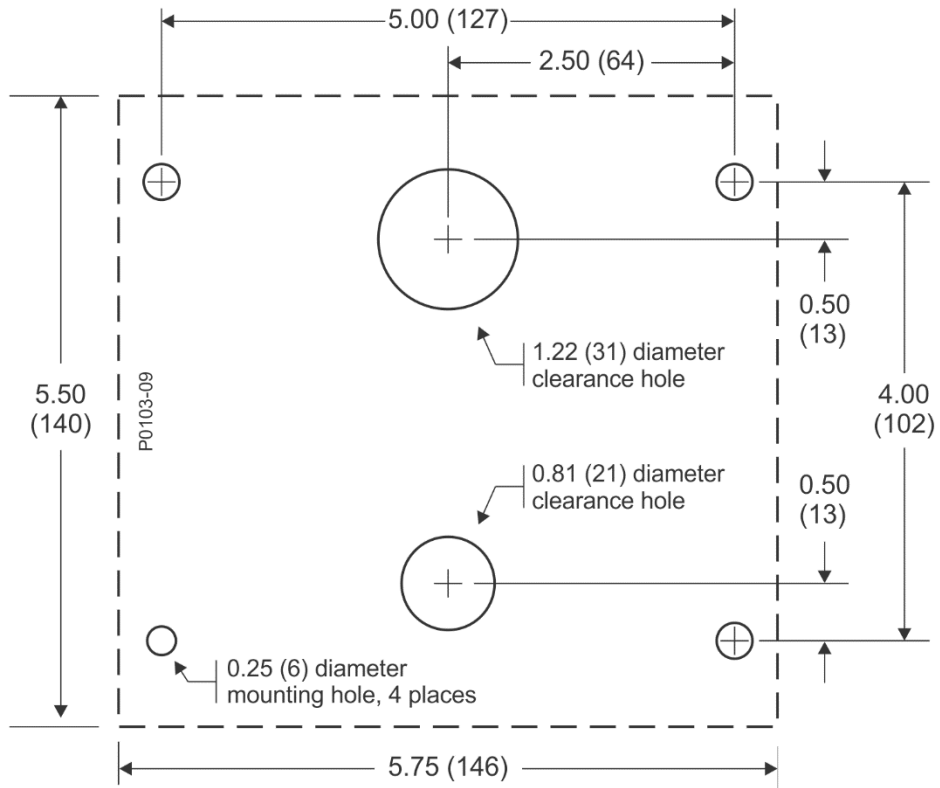
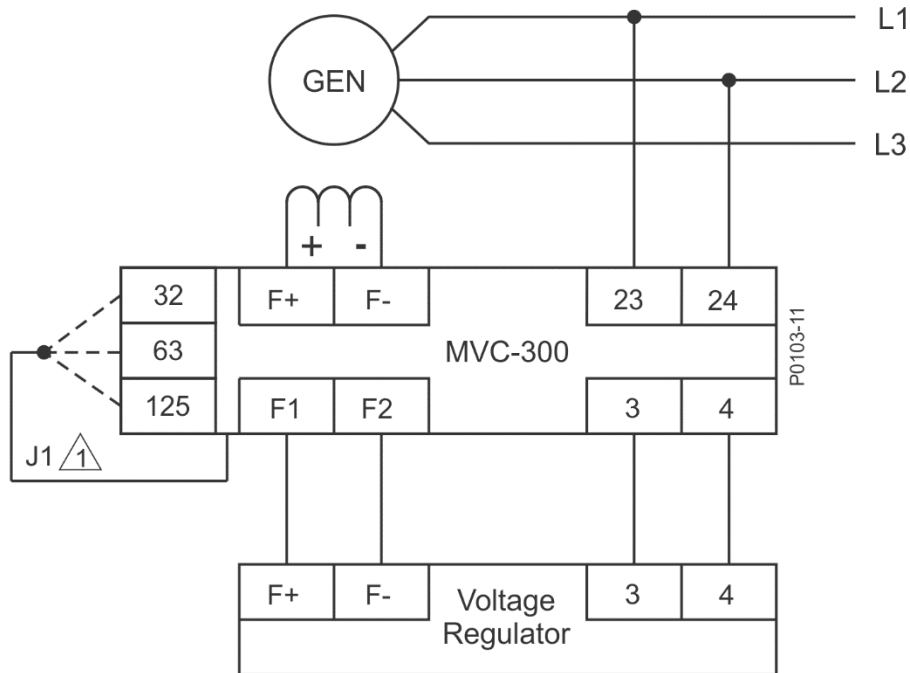

Figure 3. Drilling Dimensions for Remote Mounting of Front Panel

Connections

MVC-300 connections are made at the terminal strip located on the rear panel. The #6 terminal screws accept wire sizes over the range of 22 to 12 AWG and have a maximum torque of 9 in-lb (1 N•m). Terminal assignments are shown in Figure 1 and typical MVC-300 connections are illustrated in Figure 4.



 Jumper J1 selects the maximum field voltage. See Table 1.

Figure 4. MVC-300 Typical Connections

Applying the MVC-300 with a digital voltage regulator that relies upon field current measurement for field regulation (such as the Basler DECS-150 or DECS-250) can result in damage if connected as shown in Figure 4 and on the MVC-300 front panel. In these applications, an auto/manual control switch and diode module must be implemented as shown in Figure 5. The switch transfers control of excitation between the voltage regulator and the MVC-300. The diode module, Basler part number 9293600101, suppresses excessive field voltage buildup when the switch is operated and its contacts change state.

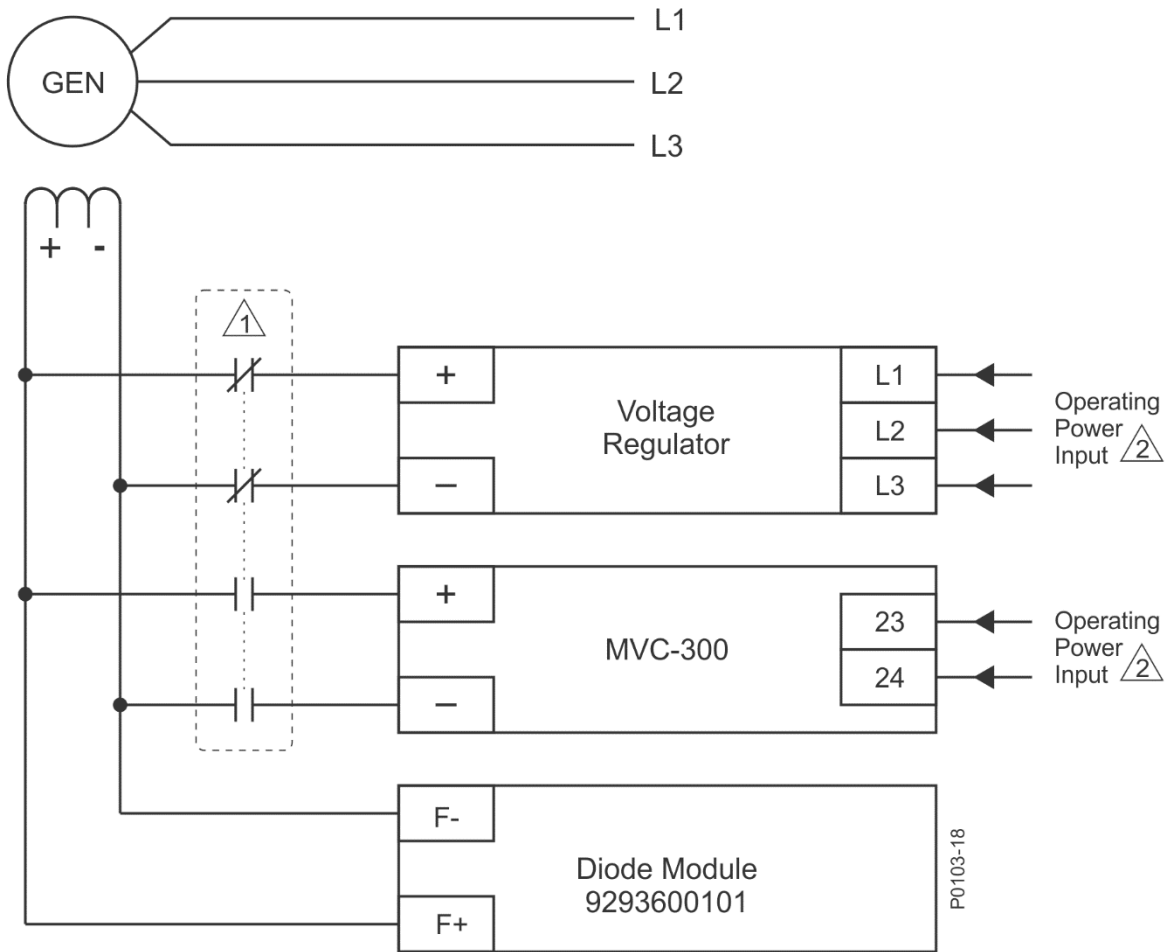

1 Auto/manual control transfer switch contacts must be rated appropriately for the field requirements.

2 Voltage regulator and MVC-300 operating power inputs can be shunt- or station-powered.

Figure 5. MVC-300 Connections with PWM Voltage Regulator

To prevent voltage regulator or MVC-300 damage, it is imperative that the MVC-300 be connected to provide an output that is compatible with the voltage regulator rating. When the MVC-300 and voltage regulator are properly matched, the MVC-300 will provide smooth control of the generator output voltage when manual operation is selected.

Use Table 1 to determine the appropriate input voltage and select the output voltage. Based on the voltage regulator model, the proper MVC-300 input rating is selected and connections are made between the generator and MVC-300 terminals 23 and 24 in order to supply the specified voltage. The MVC-300 has a wire jumper connected from the printed circuit board to the barrier strip. Connect this jumper to the appropriate Voltage Selection terminal listed in Table 1.

Table 1. Voltage Selection Chart

Voltage Regulator		MVC-300	
Model	Maximum Rating	AC Input Voltage	Voltage Selection Terminal
KR7F, KR7FF, SR8A, SR8F	125 Vdc at 7 Adc	240	125
SR4A, SR4F, KR4F, KR4FF	63 Vdc at 7 Adc	120	63
SR2001, SR2004	63 Vdc at 7 Adc	240	63
KR2F, KR2FF	32 Vdc at 7 Adc	120	32
APR63-5	63 Vdc at 7 Adc	240	63
APR125-5	125 Vdc at 7 Adc	240	125
HP63	63 Vdc at 7 Adc	240	63

Operation

With the Auto-Off-Manual mode switch placed in the Manual position, the automatic voltage regulator is removed from the line and generator output voltage is controlled manually by the MVC-300. When the mode switch is placed in the Auto position, the generator output voltage is controlled by the voltage regulator. Complete excitation shutdown occurs when the mode switch is placed in the Off position.

Warning!

With the voltage control mode switch in the Manual or Off position, some voltage regulator terminals remain connected to the generator and present a potential shock hazard. No attempt should be made to remove or troubleshoot the voltage regulator while the generator is running.

Start the prime mover and set the Manual Voltage Adjust control to minimum (fully counterclockwise) and place the Auto-Off-Manual control mode switch in the Manual position. Note that the voltage may be unstable (hunting) if the Manual Voltage Adjust control is set below 30 Vac.

Allow the generator voltage to build up and slowly increase the generator output voltage with the Manual Voltage Adjust the control until the generator voltage reaches the desired level.

Operational Test

To verify that the MVC-300 is functioning properly, perform a bench test using the connections shown in Figure 6 and the following procedure. Note that a voltage regulator is not required for this test.

1. With no power applied to the MVC-300 and all connections to the voltage regulator removed, place the MVC-300 Auto-Off-Manual mode switch in the Manual position.
2. Connect a 120 Vac, 100-watt incandescent lightbulb to MVC-300 terminals F+ and F-. Connect the MVC-300 jumper to terminal 63.
3. With the Manual Voltage Adjust control fully counterclockwise, apply a 120 Vac source to MVC-300 terminals 23 and 24. Slowly rotate the control clockwise and observe that the brightness of the lightbulb increases proportionally until it reaches full brightness.
4. Rotate the Manual Voltage Adjust control fully counterclockwise. Remove the 120 Vac source from terminals 23 and 24 and select 32 Vdc operation by moving the MVC-300 jumper to terminal 32. Apply 120 Vac to MVC-300 terminals 23 and 24 and observe that the brightness of the lightbulb increases as the Manual Voltage Adjust control is rotated clockwise. Observe that the lightbulb is at approximately half of its previous brightness when the MVC-300 jumper was connected to terminal 63.

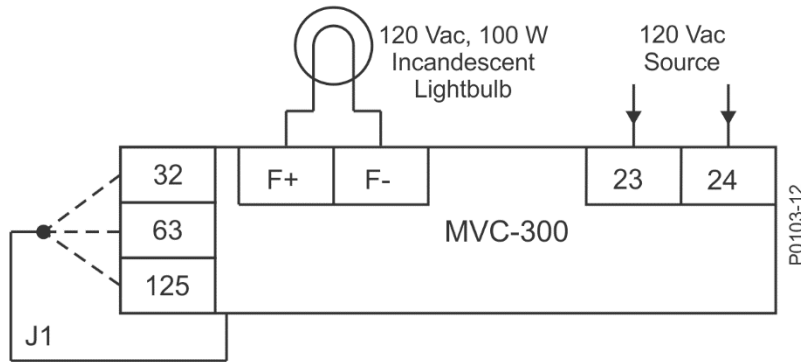

Figure 6. MVC-300 Test Connections

Maintenance

Periodic inspection should be made to ensure that the MVC-300 is clean and free from accumulations of dust and moisture. Verify that all terminal connections of the MVC-300 and voltage regulator are clean and tight.

Replacement Parts

A reasonable stock of spare parts minimizes downtime in the event of malfunction. When ordering replacement parts from Basler Electric, always specify the part number, quantity, and description of the item. MVC-300 replacement parts are listed in Table 2.

Table 2. Replacement Parts

Component Designator	Description	Part Number	Quantity
—	Printed circuit board	9121001106	1
F1, F2	Fuse, 10 A, 250 V	29514	2
R18	Potentiometer, 10 k Ω , 1 W	43692	1

Troubleshooting

Use the following troubleshooting procedures if the MVC-300 fails to operate as expected. For an MVC-300 bench test procedure, refer to *Operational Test*.

- Verify that all MVC-300 wiring is correct and in accordance with the connection diagrams of Figure 4 or Figure 5, depending upon your application.
If the wiring is incorrect or defective, correct or repair as needed.
If all wiring is correct, proceed to step 2.
- Verify that the Auto-Off-Manual control mode switch turns off the excitation.
If the excitation does not turn off, replace the MVC-300.
If the excitation shuts down, proceed to step 3.
- With the Auto-Off-Manual switch in the Manual position, verify that the generator output voltage builds up.
If the generator output voltage builds up, proceed to step 6.
If the generator output voltage does not build up, proceed to step 4.
- Verify that MVC-300 fuses F1 and F2 are not open.
If either fuse is open, replace it and proceed to step 5.
If both fuses are good, replace the MVC-300.
- Verify that the generator output voltage builds up.
If the generator output voltage does not build up, replace the MVC-300.
If the generator output voltage builds up, proceed to step 6.

6. Verify that the generator output can be controlled by the MVC-300 control potentiometer.
If the generator output voltage cannot be controlled, replace the MVC-300.
If the generator output voltage is controllable, proceed to step 7.
7. Verify that the generator operates as expected with the MVC-300 Auto-Off-Manual control mode switch in the Auto position.
If the generator fails to operate properly, troubleshoot the voltage regulator.

